



REQUEST FOR QUOTATION #2021-070

Date: _____

Name of Company: _____

Address: _____

TIN No.: _____

Please quote your best offer for the item/s described below, subject to the Terms and Conditions as stated hereunder.

- a.) Bidders shall provide correct and accurate information required in this form.
- b.) Bidders may quote for all the items.
- c.) Price quotation/s must be valid for a period of *One Hundred Twenty (120) calendar days* from the date of submission.
- d.) Price quotation/s, to be denominated in Philippine peso shall include all taxes, duties and/or levies payable.
- e.) Quotations exceeding the Approved Budget for the Contract shall be rejected.
- f.) Award of contract shall be made to the lowest quotation (for goods and infrastructure) or, the highest rated offer (for consulting services) which complies with the minimum technical specifications and other terms and conditions stated herein.
- g.) Any alterations, erasures or overwriting shall be valid only if they are signed or initiated by you or any of your duly authorized representative/s.
- h.) The work shall be done within **Sixty (60) Calendar Days** from receipt of approved Contract Agreement or Job Order and Notice to Proceed.
- i.) The BuCor shall have the right to inspect and/or to test the goods to confirm their conformity to the technical specifications.
- j.) Liquidated damages equivalent to one tenth of one percent (0.001%) of the value of the goods not delivered within the prescribed delivery period shall be imposed per day of delay. The BuCor shall rescind the contract once the cumulative amount of liquidated damages reaches ten percent (10%) of the amount of the contract, without prejudice to other courses of action and remedies open to it.
- k.) Bidders shall submit the required documents together with their bid price in a sealed envelope indicating supplier's name and name of project.
- l.) Submission thru e-mail and fax quotation **will be allowed/accepted**.

REQUIREMENTS TO BE SUBMITTED

- m.) Valid and Current PhilGeps Registration Number
- n.) Valid and Current Mayor's/Business Permit
- o.) Valid and Current PCAB License and Registration

Note:

Allow PEs to accept the expired Business or Mayor's permit with Official Receipt of renewal application, subject to submission of Business or Mayor's permit after award of contract under GPPB Resolution No. 05-2020 Approving the Acceptance of an Expired Mayor's Permit with Official Receipt for the Renewal Application.

- p.) Valid and Current Complete Income Tax Return filed thru EFPS
- q.) Duly Notarized Omnibus Sworn Statement

Note:

Unnotarized Omnibus Sworn Statement of the lone supplier is hereby approved subject to compliance therewith after award of contract but before payment under GPPB Resolution No. 09-2020 Approving Measures for the Efficient Conduct of Procurement Activities during a state of calamity, or Implementation of Community Quarantine or Similar Restrictions.

- r.) Duly Notarized Authority to Signatory (if applicable).

NOTE:

BIDDERS STATEMENT OF COMPLIANCE ON THE TERMS & CONDITIONS AND REQUIREMENTS AS STATED ABOVE

Signature over Printed Name of
Sole Proprietor /Authorized Representative

Submit your sealed quotation duly signed by you or your duly authorized representative not later than **October 22, 2021** at the BAC Office, Bureau of Corrections at **09:00 A.M.** Late submission of bids shall be rejected. For further information, you can call the BAC Secretariat c/o WILLIAM M. TERRADO at the Supply Office, Bureau of Corrections, Muntinlupa City at Tel # 809-8587/478-0907 from 8:00 am to 5:00pm or email at bacsecbucor@yahoo.com, Monday to Friday.

CCSUPT VICTOR ERICK L PASCUA
Chairperson, Bids and Awards Committee

After having carefully read and accepted the Terms and Conditions, I/we submit our quotation/s for the item/s as follows:

REQUEST FOR QUOTATION RFQ 2021-070

Project: Refurbishing/Fabrication of Bunk Beds

ABC: ₱500,000.00

QTY	UNIT	DESCRIPTION	Compliance to the Technical specifications (Please check)		Unit Price	Offered Quotation	Approved Budget of the Contract (ABC)
			YES	NO			
1	Lot	Refurbishing/Fabrication of Bunk Beds					₱500,000.00

SIGNATURE OVER PRINTED NAME OF SOLE PROPRIETOR OR REPRESENTATIVE

TELEPHONE NO: _____

CELLPHONE NO: _____

EMAIL: _____

COMPANY LETTERHEAD

Omnibus Sworn Statement

REPUBLIC OF THE PHILIPPINES)
CITY/MUNICIPALITY OF _____) S.S.

A F F I D A V I T

I, *[Name of Affiant]*, of legal age, *[Civil Status]*, *[Nationality]*, and residing at *[Address of Affiant]*, after having been duly sworn in accordance with law, do hereby depose and state that:

1. ***Select one, delete the other:***

If a sole proprietorship: I am the sole proprietor or authorized representative of *[Name of Bidder]* with office address at *[address of Bidder]*;

If a partnership, corporation, cooperative, or joint venture: I am the duly authorized and designated representative of *[Name of Bidder]* with office address at *[address of Bidder]*;

2. ***Select one, delete the other:***

a) *If a sole proprietorship:* As the owner and sole proprietor, or authorized representative of *[Name of Bidder]*, I have full power and authority to do, execute and perform any and all acts necessary to participate, submit the bid, and to sign and execute the ensuing contract for ***Refurbishing/Fabrication of Bunk Beds*** of the **Bureau of Corrections**, as shown in the attached duly notarized *Special Power of Attorney*;

b) *If a partnership, corporation, cooperative, or joint venture:* I am granted full power and authority to do, execute and perform any and all acts necessary to participate, submit the bid, and to sign and execute the ensuing contract for ***Refurbishing/Fabrication of Bunk Beds*** of the **Bureau of Corrections**, as shown in the attached *[state title of attached document showing proof of authorization (e.g., duly notarized Secretary's Certificate, Board/Partnership Resolution, or Special Power of Attorney, whichever is applicable);]*;

3. *[Name of Bidder]* is not "blacklisted" or barred from bidding by the Government of the Philippines or any of its agencies, offices, corporations, or Local Government Units, foreign government/foreign or international financing institution whose blacklisting rules have been recognized by the Government Procurement Policy Board by itself or by relation, membership, association, affiliation, or controlling interest with another blacklisted person or entity as defined and provided for in the Uniform Guidelines on Blacklisting ;

4. Each of the documents submitted in satisfaction of the bidding requirements is an authentic copy of the original, complete, and all statements and information provided therein are true and correct;

5. *[Name of Bidder]* is authorizing the Head of the Procuring Entity or its duly authorized representative(s) to verify all the documents submitted;

6. ***Select one, delete the rest:***

If a sole proprietorship: The owner or sole proprietor is not related to the Head of the Procuring Entity, members of the Bids and Awards Committee (BAC), the Technical Working Group, and the BAC Secretariat, the head of the Project Management Office or the end-user unit, and the project consultants by consanguinity or affinity up to the third civil degree;

If a partnership or cooperative: None of the officers and members of *[Name of Bidder]* is related to the Head of the Procuring Entity, members of the Bids and Awards Committee (BAC), the Technical Working Group, and the BAC Secretariat, the head of the Project Management Office or the end-user unit, and the project consultants by consanguinity or affinity up to the third civil degree;

If a corporation or joint venture: None of the officers, directors, and controlling stockholders of [*Name of Bidder*] is related to the Head of the Procuring Entity, members of the Bids and Awards Committee (BAC), the Technical Working Group, and the BAC Secretariat, the head of the Project Management Office or the end-user unit, and the project consultants by consanguinity or affinity up to the third civil degree;

7. [*Name of Bidder*] complies with existing labor laws and standards; and
8. [*Name of Bidder*] is aware of and has undertaken the following responsibilities as a Bidder:
 - a) Carefully examine all of the Bidding Documents;
 - b) Acknowledge all conditions, local or otherwise, affecting the implementation of the Contract;
 - c) Made an estimate of the facilities available and needed for the contract to be bid, if any; and
 - d) Inquire or secure Supplemental/Bid Bulletin(s) issued for the ***Refurbishing/Fabrication of Bunk Beds.***
9. [*Name of Bidder*] did not give or pay directly or indirectly, any commission, amount, fee, or any form of consideration, pecuniary or otherwise, to any person or official, personnel or representative of the government in relation to any procurement project or activity.
10. In case advance payment was made or given, failure to perform or deliver any of the obligations and undertakings in the contract shall be sufficient grounds to constitute criminal liability for Swindling (Estafa) or the commission of fraud with unfaithfulness or abuse of confidence through misappropriating or converting any payment received by a person or entity under an obligation involving the duty to deliver certain goods or services, to the prejudice of the public and the government of the Philippines pursuant to Article 315 of Act No. 3815 s. 1930, as amended, or the Revised Penal Code.

IN WITNESS WHEREOF, I have hereunto set my hand this ___ day of ___, 2021 at _____, Philippines.

Bidder's Representative/Authorized Signatory

SUBSCRIBED AND SWORN to before me this ___ day of [*month*] [*year*] at [*place of execution*], Philippines. Affiant/s is/are personally known to me and was/were identified by me through competent evidence of identity as defined in the 2004 Rules on Notarial Practice (A.M. No. 02-8-13-SC). Affiant/s exhibited to me his/her [*insert type of government identification card used*], with his/her photograph and signature appearing thereon, with no. _____ and issued on _____ at _____.

Witness my hand and seal this ___ day of [*month*] [*year*].

NAME OF NOTARY PUBLIC

Serial No. of Commission _____

Notary Public for _____ until _____

Roll of Attorneys No. _____

PTR No. _____ [*date issued*], [*place issued*]

IBP No. _____ [*date issued*], [*place issued*]

Doc. No. _____

Page No. _____

Book No. _____

Series of _____

SCOPE OF WORK	
REFURBISHING/FABRICATION OF BUNK BEDS	
BUREAU OF CORRECTIONS, N.B.P. RESERVATION MUNTINLUPA CITY	
CIVIL ENGINEERING UNIT	
ITEM No.	DESCRIPTION
1.0	Welding & Painting Works
	<i>Scope of Works:</i>
	<i>1. Use 3.2mm THK angle Bar and flat bar (see detailed plan for sizes)</i>
	<i>2. Use 3/4" THK GI pipe sch 20 for Guard Rail and Stairs</i>
	<i>3. Use 1/2" Phenolic Board as bed (lower and upper)</i>
	<i>4. Use M10 Hexagonal bolt 10mmx30mm with nut and washer (for framing of 25mmx25mmx3.2mm Bed Frame & Flat Bar connections)</i>
	<i>5. Use Epoxy primer w/ reducer for 2 coats</i>
	<i>6. Use Solvent semi gloss paint for final coating (2 coats) color must be approved by the end user</i>
	<i>7. Use Welding rod electrode no. 6011 for all welding parts</i>

Project Duration: 60 calendar days

CONFORME:

Name of Company in Print

Signature Printed Name of Authorized Representative/Date

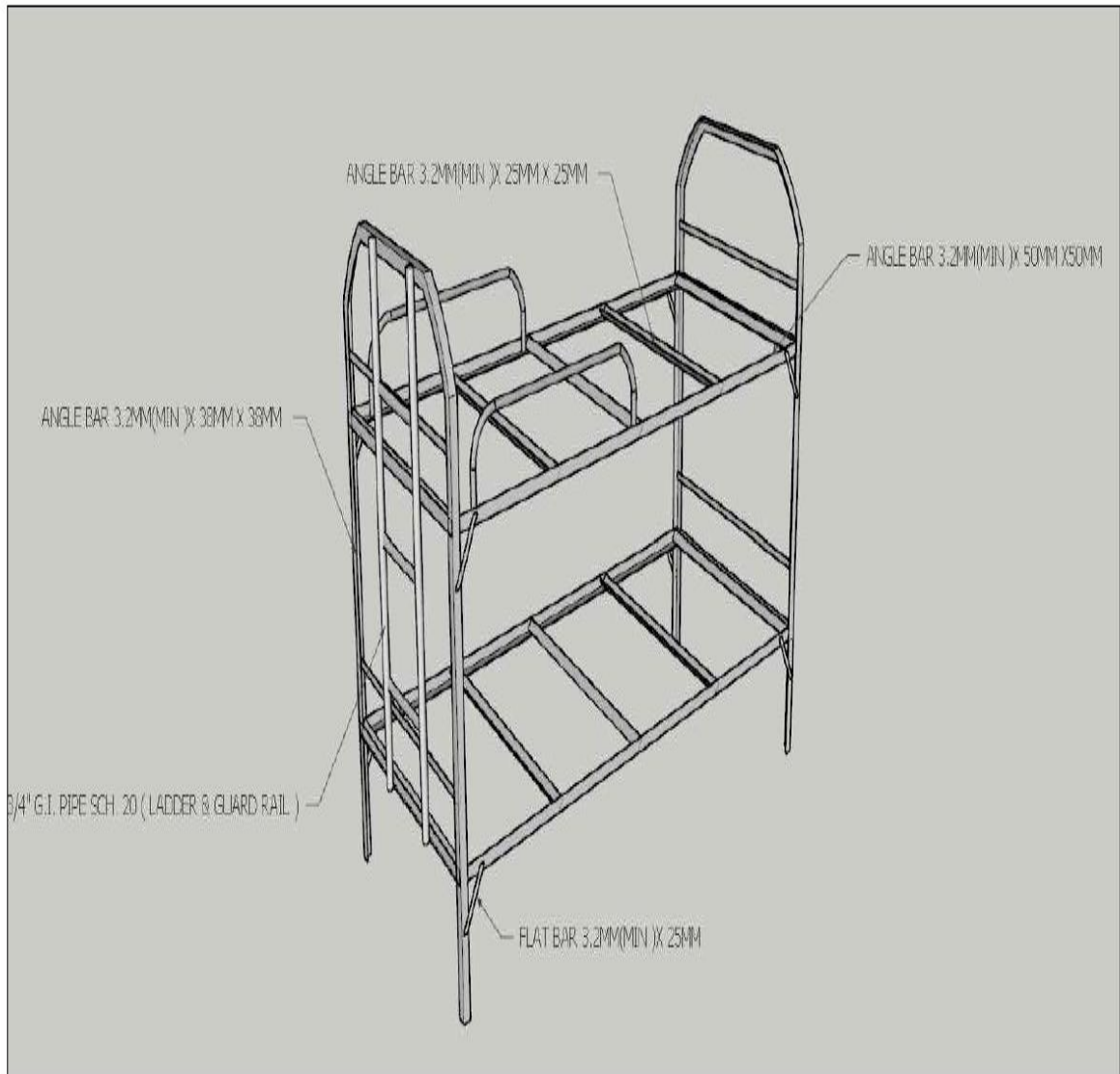

REFURBISHING/ FABRICATION OF BUNKBEDS

CONFORME:

Name of Company in Print

Signature Printed Name of Authorized Representative/Date

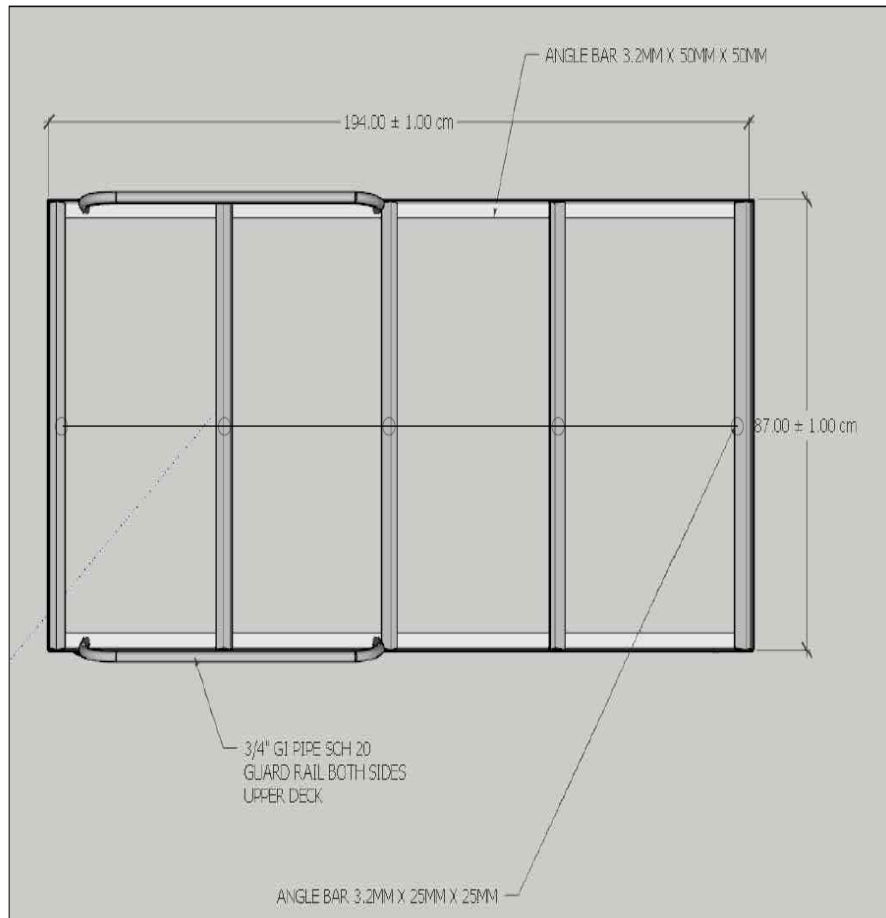

REFURBISHING/ FABRICATION OF BUNKBEDS

CONFORME:

Name of Company in Print

Signature Printed Name of Authorized Representative/Date

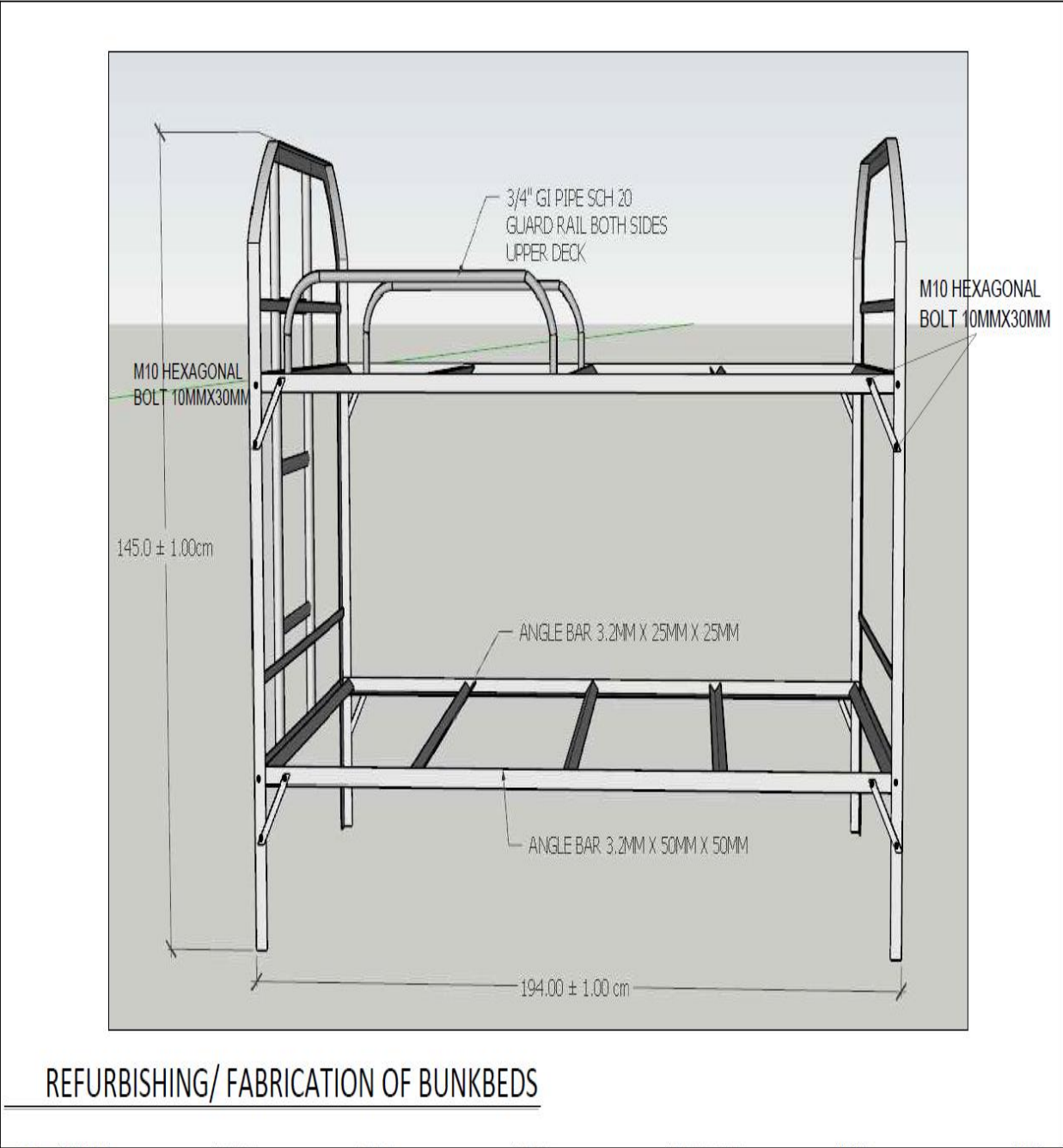

CONFORME:

Name of Company in Print

Signature Printed Name of Authorized Representative/Date

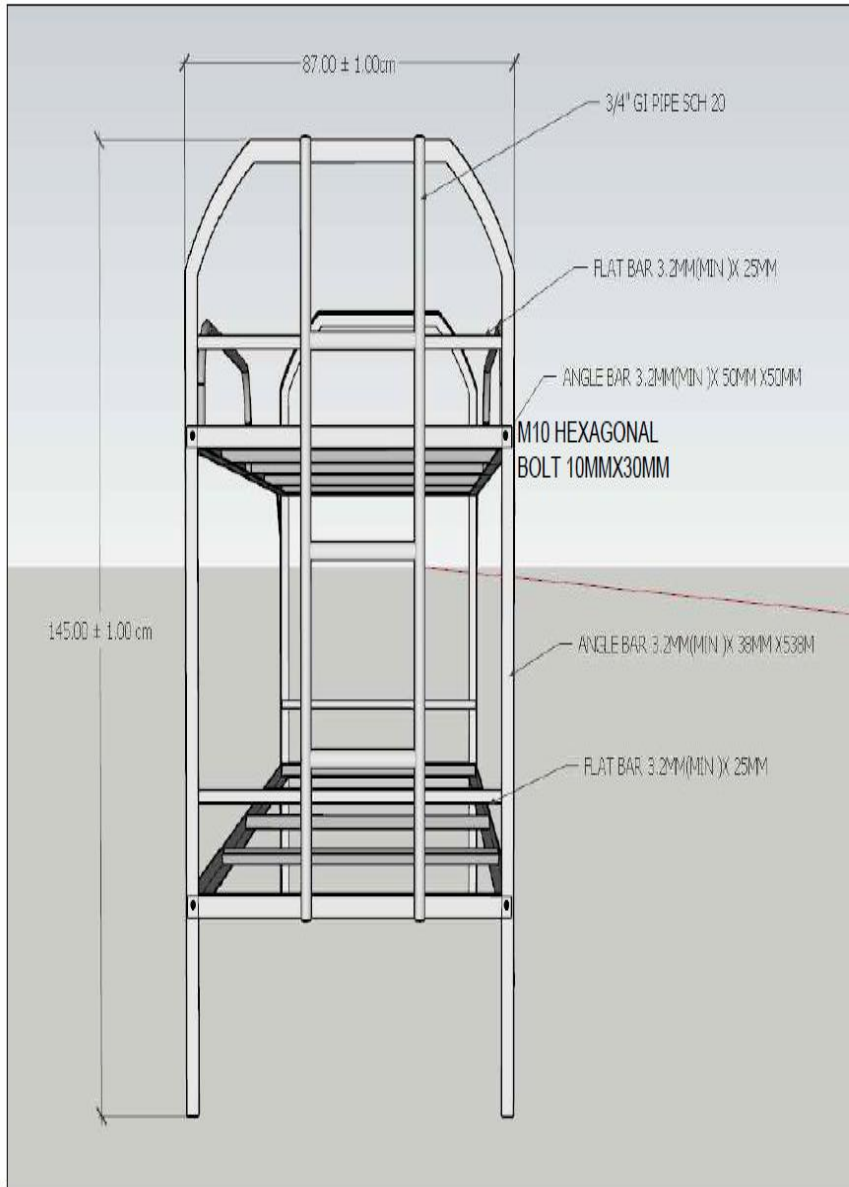

REFURBISHING/ FABRICATION OF BUNKBEDS

CONFORME:

Name of Company in Print

Signature Printed Name of Authorized Representative/Date



Republic of the Philippines
 Department of Justice
BUREAU OF CORRECTIONS
 Muntinlupa City



PROJECT TITLE : REFURBISHING/FABRICATION OF BUNK BEDS

BILL OF QUANTITIES

ITEM	DESCRIPTION	Qty	Unit	Unit Cost	Amount
1	A. WELDING & PAINTING WORKS (QTY: 35 UNITS)	1	Lot		
Total Direct Cost:					
Overhead,Contingencies, Miscellaneous:					
Contractor's Profit:					
Mobilization/Demobilization:					
Value Added Tax:					
Total Project Cost:					

Submitted by:

 Contractor/Authorized Representative