



Republic of the Philippines
Department of Justice
BUREAU OF CORRECTIONS
Muntinlupa City



PHILIPPINE BIDDING DOCUMENTS

Government of the
Republic of the Philippines

Procurement of INFRASTRUCTURE PROJECTS

First Edition
May 2025
Bids and Awards Committee 2026

Preface

These Philippine Bidding Documents (PBD) for the procurement of Infrastructure Projects (hereinafter referred to also as the “Works”) through **Competitive Bidding** have been prepared by the Government of the Philippines (GoP) for use by all branches, agencies, departments, bureaus, offices, or instrumentalities of the Government, including government-owned and/or -controlled corporations (GOCC), government financial institutions (GFI), state universities and colleges (SUC), local government units (LGU), and autonomous regional government. The procedures and practices presented in this document have been developed through broad experience, and are for mandatory¹ use in projects that are financed in whole or in part by the GoP or any foreign government/foreign or international financing institution in accordance with the provisions of the Implementing Rules and Regulations (IRR) of Republic Act No. 12009 (RA No. 12009).

This PBD is intended as a model for admeasurements (unit prices or unit rates in a bill of quantities) types of contract, which are the most common in Works contracting.

The Bidding Documents shall clearly and adequately define, among others: (a) the objectives, scope, and expected outputs and/or results of the proposed contract; (b) the eligibility requirements of Bidders; (c) the expected contract duration; and (d) the obligations, duties, and/or functions of the winning bidder.

In order to simplify the preparation of the Bidding Documents for each procurement, the PBD groups the provisions that are intended to be used unchanged in Section II. Instructions to Bidders (ITB) and in Section IV. General Conditions of Contract (GCC). Data and provisions specific to each procurement and contract should be included in Section III. Bid Data Sheet (BDS); Section V. Special Conditions of Contract (SCC); Section VI. Specifications; Section VII. Drawings; and Section VIII. Bill of Quantities. The forms to be used are provided in Section IX. Philippine Bidding Documents Related Forms.

Prudence must be exercised to check the relevance of the provisions of the PBD against the requirements of the specific Works to be procured. In addition, each Section is prepared with notes intended only as information for the Procuring Entity or the person drafting the Bidding Documents. They shall not be included in the final documents, except for the notes introducing Section IX. Philippine Bidding Documents Related Forms, where the information is useful for the Bidder. The following general directions should be observed when using the documents:

- a) All the documents listed in the Table of Contents are normally required for the procurement of Infrastructure Projects. However, they should be adapted as necessary to the circumstances of the particular Project.
- b) Specific details, such as the “name of the Procuring Entity” and “address for proposal submission,” should be furnished in the BDS and SCC. The final documents should contain neither blank spaces nor options.
- c) This Preface and the footnotes, or notes in italics included in the Invitation to Bid, BDS, SCC, Specifications, Drawings, and Bill of Quantities are not part of the text of the final document, although they contain instructions that the Procuring Entity should strictly follow. The Bidding Documents should not

¹ *Unless the Treaty or International or Executive Agreement expressly provides use of foreign government/foreign or international financing institution procurement guidelines.*

contain footnotes except Section IX. Philippine Bidding Documents Related Forms since these provide important guidance to Bidders.

- d) The cover page should be modified as required to identify the Bidding Documents and date of issue.
- e) The Project title page should be modified as required to identify the Project title and number, name and address of the Procuring Entity.
- f) If modifications must be made to the bidding requirements, they can be presented in the BDS. Modifications for specific Project or Contract details should be provided in the SCC as amendments to the Conditions of Contract. For easy completion, whenever reference has to be made to specific clauses in the BDS or SCC, these terms shall be printed in bold type face on Section II. Instructions to Bidders, and Section IV. General Conditions of Contract, respectively. To facilitate easy reference and completion, clauses from the BDS and SCC shall appear in bold type face in Sections II and IV, respectively.



Republic of the Philippines
Department of Justice
BUREAU OF CORRECTIONS
Muntinlupa City



Procurement of INFRASTRUCTURE PROJECTS

DESIGN AND BUILD OF BUCOR REGIONAL FACILITY ONE (1) UNIT 3-STOREY TYPE B DORMITORY- PHASE 5

Project Identification Number:2026-010

TABLE OF CONTENTS

Section I. Invitation to Bid..... 6
Section II. Instructions to Bidders..... 10
Section III. Bid Data Sheet..... 37
Section IV. General Conditions of Contract..... 48
Section V. Special Conditions of Contract 76
Section VI. Specifications 81
Section VII. Drawings 123
Section VIII. Bill of Quantities 124
Section IX. Philippine Bidding Documents Related Forms 126

Section I. Invitation to Bid



Republic of the Philippines
Department of Justice
BUREAU OF CORRECTIONS
Muntinlupa City



Invitation to Bid for DESIGN AND BUILD OF BUCOR REGIONAL FACILITY ONE (1) UNIT 3-STOREY TYPE B DORMITORY- PHASE 5

- 1) The **Bureau of Corrections**, through the **SARO-BMB-D-25-0017303** dated **November 27, 2025** intends to apply the sum of **Three Hundred Million Pesos Only (P300,000,000.00)** being the Approved Budget for the Contract (ABC) to payments under the contract for **Design and Build of BUCOR Regional Facility One (1) Unit 3-Storey Type B Dormitory- Phase 5**. Bids received in excess of the ABC shall be automatically rejected at bid opening.
- 2) The **Bureau of Corrections** now invites bids for the project adopting a Design and Build scheme, wherein the contractor is responsible for both the comprehensive detailed design and actual construction of the project. The total project duration is **Three Hundred Sixty-Five (365) Calendar Days (12 Months)** from the date of issuance of Notice to Proceed, inclusive of the preparation of plans, securing necessary permits, and full completion of civil works. Bidders should have completed a contract similar to the Project amounting to at **least fifty percent (50%)** of the ABC **within the last four (4) years**. The description of an eligible bidder is contained in the Bidding Documents, particularly, in Section II. Instructions to Bidders (ITB).
- 3) Bidding will be conducted through competitive bidding procedures using a non-discretionary “pass/fail” criterion as specified in the IRR, otherwise known as the “New Government Procurement Act (NGPA)”.

Bidding is restricted to Filipino citizens/sole proprietorships, cooperatives, and partnerships or organizations with at least sixty percent (60%) interest or outstanding capital stock belonging to citizens of the Philippines.

- 4) Interested bidders may obtain further information from **Bureau of Corrections** and inspect the Bidding Documents at the address given below from **Monday to Friday from 8:00am to 5:00pm**.
- 5) A complete set of Bidding Documents may be acquired by interested bidders on **14 April 2026 (0800H to 1700H to 05 May 2026 (0800H to 0959H)** from the address below and upon payment of the applicable fee for the Bidding Documents, pursuant to the latest Guidelines issued by the GPPB, in the amount of **Fifty Thousand (P50,000.00) Pesos**.

It may also be downloaded free of charge from the website of the Philippine Government Electronic Procurement System (PhilGEPS) and the website of the Procuring Entity **bucor.gov.ph**, provided that bidders shall pay the applicable fee for the Bidding Documents not later than the submission of their bids.

- 6) The **Bureau of Corrections** will hold a Pre-Bid Conference on **22 April 2026 (1000H)** at **BAC Conference Room, National Headquarters, NBP Reservation, Poblacion, Muntinlupa City**, which shall be open to prospective bidders.

- 7) Bids must be duly received by the Bids and Awards Committee (BAC) Secretariat through manual submission at the address indicated below on or before **05 May 2026 (0959H)**. Late bids shall not be accepted.
- 8) All Bids must be accompanied by a Bid Security in any of the acceptable forms and in the amount stated in **ITB** Clause 16.
- 9) Bid opening shall be on **05 May 2026 (1000H)** at **BAC Conference Room, National Headquarters, NBP Reservation, Poblacion, Muntinlupa City**. Bids will be opened in the presence of the Bidders' representatives who choose to attend the activity.
- 10) The Criteria for the Contract Award is **Most Economically Advantageous Responsive Bid (MEARB)**.

- **WEIGHTED TECHNICAL SCORE (WTS) EVALUATION CHECKLIST WITH POINTING SYSTEM (70%)**

Weighted Technical Score Evaluation: Technical Description Score x 0.70
(RA 12009 IRR – MEARB)

Technical Description	Points
1. QUALITY AND TECHNICAL MERIT	20%
2. AESTHETIC AND FUNCTIONAL DESIGN	15%
3. APPROACH AND METHODOLOGY	15%
4. ACCESSIBILITY	5%
5. TOOLS, EQUIPMENT, AND TECHNOLOGY	5%
6. SOCIAL, ENVIRONMENTAL, ECONOMIC, AND INNOVATIVE CHARACTERISTICS	10%
7. ORGANIZATION, QUALIFICATION, AND EXPERIENCE OF ASSIGNED PERSONNEL	15%
8. ONGOING CONTRACTS AND WORK COMMITMENTS	5%
9. AFTER-SALES SERVICE / TECHNICAL ASSISTANCE	5%
10. DELIVERY CONDITIONS (PERIOD AND PROCESS)	2.5%
11. DISPOSAL MEASURES	2.5%
TOTAL:	100%

- **PRICE SCORE (PS) EVALUATION (30%)**

(RA 12009 IRR – MEARB)

Price Score Formula:

$$\text{Price Score (PS)} = \left(\frac{\text{Lowest Bid}}{\text{Bid price of Evaluated Bid}} \right) \times \text{Price weight (30\%)}$$

- **TOTAL MEAB SCORE:**

Total score (TS)= Weighted Technical Score (WTS) + Price Score (PS)

- Only the bidder's second envelope obtaining the top three (3) highest technical rating shall be opened.
- 11) The **Bureau of Corrections** reserves the right to reject any and all bids, declare a failure of bidding, or not award the contract at any time prior to contract award in accordance with Section 70 of R.A. No. 12009, without thereby incurring any liability to the affected bidder or bidders.
 - 12) For further information, please refer to:

MARIA ADORACION VIÑAS
Office of the BAC Secretariat
Bureau of Corrections
National Headquarters, NBP Reservation, Poblacion, Muntinlupa City
Tel # 02-8809-8587/02-8478-0907/02-8659-0833
bacsec2022@gmail.com
 - 13) You may visit the following websites:
For downloading of Bidding Documents: bucoor.gov.ph

Date of Issue: _____

CCSUPT MELENCIO S FAUSTINO
Chairman, Bids and Awards Committee

Section II. Instructions to Bidders

A. General

1) Scope of Bid

- 1.1 The Procuring Entity named in the **BDS**, invites Bids for the [insert Procurement Project], with Project Identification Number [indicate number].

The Procurement Project (referred to herein as "Project") is for the construction of Works, as described in Section VI (Specifications).

- 1.2 The winning Bidder will be expected to complete the Works by the intended completion date specified in **SCC** Clause 1.1.

2) Source of Funds

The Procuring Entity has a budget or received funds from the Funding Source named in the **BDS**, and in the amount indicated in the **BDS**. It intends to apply part of the funds received for this Project to cover eligible payments under the contract.

3) Corrupt, Fraudulent, Collusive, Coercive, and Obstructive Practices

- 3.1 Unless otherwise specified in the **BDS**, the Procuring Entity, as well as Bidders and Contractors, shall observe the highest standard of ethics during the procurement and execution of the contract. In pursuance of this policy, the Procuring Entity:

- a) defines, for purposes of this provision, the following terms under existing laws, rules, and regulations:
 - i) "corrupt practice" means an act by which officials in the public or private sectors improperly and unlawfully enrich themselves, others, or induce others to do so, by misusing the position in which they are placed, and includes the offering, giving, receiving, or soliciting of anything of value to influence the action of any such official in the procurement process or in contract execution; entering, on behalf of the government, into any contract or transaction manifestly and grossly disadvantageous to the same, whether or not the public officer profited or will profit thereby, and similar acts as provided in RA No. 3019.
 - ii) "fraudulent practice" means a misrepresentation of facts for purposes of influencing a procurement process or the execution of a contract to the detriment of the Procuring Entity, which includes collusive practices among Bidders (prior to or after bid submission) designed to establish bid prices at artificial, non-competitive levels and to deprive the Procuring Entity of the benefits of free and open competition.
 - iii) "collusive practices" means a scheme or arrangement between two or more Bidders, with or without the knowledge of the Procuring Entity, designed to establish bid prices at artificial, non-competitive levels.
 - iv) "coercive practices" means harming or threatening to harm, directly or indirectly, persons, or their property to influence their

participation in a procurement process, or affect the execution of a contract;

- v) "obstructive practice" is
 - a) deliberately destroying, falsifying, altering or concealing of evidence material to an administrative proceedings or investigation or making false statements to investigators in order to materially impede an administrative proceedings or investigation of the Procuring Entity or any foreign government/foreign or international financing institution relative to allegations of a corrupt, fraudulent, coercive or collusive practice; and/or threatening, harassing or intimidating any party to prevent the latter from disclosing its knowledge of matters relevant to the administrative proceedings or from pursuing such proceedings or investigation; or
 - b) acts intended to materially impede the exercise of the inspection and audit rights of the Procuring Entity or any foreign government/foreign or international financing institution herein.
- b) Undertakes to reject a proposal for award upon *prima facie* determination that the Bidder recommended for award has engaged in any of the prohibited practices mentioned in this Clause for purposes of competing for the contract.

3.2 Further, the Procuring Entity will seek to impose the maximum civil, administrative, and/or criminal penalties available under the applicable laws on individuals and organizations deemed to be involved in any of the practices mentioned in **ITB** Clause 4.

3.3 Furthermore, the Funding Source and the Procuring Entity reserve the right to inspect and audit records and accounts of a Bidder or Contractor in the bidding for and performance of a contract themselves or through independent auditors as reflected in the **GCC** Clause 36.

4) Conflict of Interest

4.1 All Bidders found to have conflicting interests shall be disqualified to participate in the procurement at hand, without prejudice to the imposition of appropriate administrative, civil, and criminal sanctions. A Bidder may be considered to have conflicting interests with another Bidder in any of the events described in paragraphs (a) through (c) and a general conflict of interest in any of the circumstances set out in paragraphs (d) through (f) below:

- a) A Bidder has controlling shareholders or beneficial owners in common with another Bidder;
- b) A Bidder receives or has received any direct or indirect subsidy from any other Bidder;
- c) A bidder has the same legally authorized representative as that of another Bidder for purposes of this Bid;

- d) A bidder has a relationship, directly or through third parties, that puts them in a position to have access to information about or influence on the bid of another Bidder or influence the decisions of the Procuring Entity regarding this bidding process. This may include a firm or an organization that lends, or temporarily seconds, its personnel to firms or organizations that are engaged in consulting services for the preparation related to procurement for or implementation of the project if the personnel would be involved in any capacity on the same project;
 - e) A bidder who participated as a consultant in the preparation of the design or technical specifications of the goods and related services that are the subject of the bid; or
 - f) A bidder who lends, or temporarily seconds, its personnel to firms or organizations which are engaged in consulting services for the preparation related to procurement for or implementation of the project, if the personnel would be involved in any capacity on the same project.
- 4.2 All Bidding Documents shall be accompanied by an Omnibus Sworn Statement of the Bidder that it is not related, by consanguinity or affinity up to the third civil degree, to the HoPE, Procurement Agent (if engaged), the head of the Project Management Office (PMO), the End-User or Implementing Unit or any members of the Bids and Awards Committee (BAC), Technical Working Group (TWG), and BAC Secretariat.²
- 4.3 The Bidder shall also disclose the ultimate beneficial ownership of the entity it represents. Failure to comply shall be a ground for the automatic disqualification of the bid in consonance with Section 59 of the IRR. For this reason, relationship to the aforementioned persons within the third civil degree of consanguinity or affinity shall automatically disqualify the Bidder from participating in the procurement of contracts of the Procuring Entity notwithstanding the act of such persons inhibiting themselves from the procurement process. This Clause shall apply to the following persons and affiliates:
- a) In the case of individuals or sole proprietorships, to the Bidders and their spouses;
 - b) In the case of partnerships, to the partnership itself and its partners;
 - c) In the case of cooperatives, to the cooperative itself and members of the board of directors, general manager or chief executive officer;
 - d) In the case of a partnership, joint venture, or consortium, to the entity itself, its members or partners, as well as any person or entity that is a member of a blacklisted partnership, joint venture, or consortium; and
 - e) In the case of corporations, a single stockholder, together with their relatives up to the third civil degree of consanguinity or affinity, and their assignees, holding at least twenty percent (20%) of the shares therein, its chairperson and president, shall be blacklisted after they have been determined to hold the same controlling interest in a previously

² Section 81.1 of the IRR.

blacklisted corporation or in two corporations that have been blacklisted; the corporations of which they are part shall also be blacklisted.

5) Eligible Bidders

- 5.1 Only Bids found to be legally, technically, and financially eligible will be evaluated. For procurement of Infrastructure Projects, the following persons shall be eligible to participate in this bidding:
- a) Duly licensed Filipino citizens or sole proprietorships;
 - b) Partnerships duly organized under the laws of the Philippines and of which at least sixty percent (60%) of the interest belongs to citizens of the Philippines;
 - c) Corporations duly organized under the laws of the Philippines, and of which at least sixty percent (60%) of the outstanding capital stock belongs to citizens of the Philippines;
 - d) Cooperatives duly organized under the laws of the Philippines; and
 - e) Persons or entities forming themselves into a Joint Venture (JV), i.e., a group of two (2) or more persons or entities that intend to be jointly and severally responsible or liable for a particular contract; Provided, however, that in accordance with relevant laws, rules, and regulations, Filipino ownership or interest of the joint venture concerned shall be at least sixty percent (60%); Provided, further, that joint ventures in which Filipino ownership or interest is less than sixty percent (60%) may be eligible where the structures to be built require the application of techniques or technologies which are not adequately possessed by a person or entity meeting the sixty percent (60%) Filipino ownership requirement; Provided, furthermore, that in the latter case, Filipino ownership or interest shall not be less than twenty-five percent (25%). For this purpose, Filipino ownership or interest shall be based on the contributions of each of the member of the joint venture as specified in their Joint Venture Agreement (JVA); Provided, finally, that the primary purpose of each member of the joint venture must be similar or related to the requirement of the project to be bid out.
- 5.2 The Procuring Entity may also invite foreign bidders when provided for under any Treaty or International or Executive Agreement as specified in the **BDS**.
- 5.3 In accordance with RA No. 4566 or the "Contractors' License Law" as amended by RA No. 11711 or "An Act Further Amending Republic Act No. 4566", the persons or entities enumerated in Section 52 of the IRR may participate in the procurement of Infrastructure Projects if it has been issued a license by the Philippine Contractors Accreditation Board (PCAB) to engage or act as a contractor.
- 5.4 The Bidder must have completed an SLCC that is similar to the procurement project to be bid, and whose value must be equivalent to at least fifty percent (50%) of the ABC, adjusted to current prices using the Philippine Statistics Authority (PSA) consumer price indices; Provided, that any change to the fifty percent (50%) requirement may be allowed, subject to the recommendation of

the Procuring Entity, which shall be submitted to the GPPB for consideration; Provided, further, that contractors under Small A and Small B categories without similar experience on the procurement project to be bid may be allowed to bid if the cost of such contract is not more than the Allowable Range of Contract Cost of their registration based on the guidelines as prescribed by the PCAB.

For foreign-funded procurement, the GoP and the foreign government, or foreign or international financing institution may agree on another track record requirement, as specified in the **BDS**.

Moreover, a contract shall be considered similar to the procurement project if it has the same major categories of work. The Procuring Entity may clarify in the Bidding Documents what is regarded as major categories of work, guided by the principle of proportionality and Fit-for-Purpose approach.

- 5.5 The SLCC shall be supported by an Owner's Certificate of Final Acceptance issued by the project owner other than the Contractor, or a final rating of at least Satisfactory in the Constructors Performance Evaluation System (CPES), or a similar performance and monitoring system. In the case of contracts with the private sector, an equivalent document shall be submitted.
- 5.6 The computation of a bidder's NFCC must be at least equal to the ABC to be bid, calculated as follows:

NFCC = [(Current assets minus current liabilities) (15)] minus the value of all outstanding or uncompleted portions of the projects under ongoing contracts, including awarded contracts yet to be started, coinciding with the procurement project to be bid; Provided, that a different formula may be adopted subject to the recommendation of the Procuring Entity, which shall be submitted to the GPPB for consideration.

The value of the domestic bidder's current assets and current liabilities shall be based on the latest AFS submitted to the BIR.

For purposes of computing the foreign bidders' NFCC, the value of the current assets and current liabilities shall be based on their latest AFS prepared in accordance with international financial reporting standards.

6) Bidder's Responsibilities

- 6.1 The Bidder or its duly authorized representative shall submit a sworn statement in the form prescribed in Section IX. Philippine Bidding Documents Related Forms as required in **ITB** Clause 12.1(h)(iv).
- 6.2 Before submitting their bids, the Bidders are deemed to be knowledgeable of all existing laws, decrees, ordinances, acts and regulations of the Philippines which may affect this Project in any way.
- 6.3 The Bidder undertook the following responsibilities:
- a) Took steps to carefully examine and ensure full understanding and comprehension of the Bidding Document, its requirements, clauses, and provisions;

- b) Acknowledged all conditions, local or otherwise, affecting the implementation of the contract;
- c) Made an estimate of the facilities available and needed for the contract to be bid, if any;
- d) Complied with its responsibility to inquire or secure Supplemental Bid Bulletin(s);
- e) Ensured that it is not “blacklisted” or barred from bidding by the Government of the Philippines (GoP) or any of its agencies, offices, corporations, or LGUs, including foreign government, or foreign/international financing institutions whose blacklisting rules have been recognized by the GPPB; by itself or by reason of its relation, membership, association, affiliation, or controlling interest with another blacklisted person or entity;
- f) Ensured that each of the documents submitted in satisfaction of the bidding requirements is an authentic copy of the original, complete, and that all statements and information provided therein are true and correct;
- g) Authorized the HoPE or its duly authorized representative/s to verify all the documents submitted;
- h) Ensured that the signatory is the duly authorized representative of the Bidder, and granted full power and authority to do, execute and perform any and all acts necessary to participate, submit the bid, to sign, and execute the ensuing contract, accompanied by the duly notarized Special Power of Attorney, Board or Partnership Resolution, or Secretary’s Certificate, whichever is applicable;
- i) Complied with the disclosure provision under Section 81 and 82 of RA No. 12009 and its IRR in relation to other provisions of RA No. 3019;
- j) Complied with existing labor laws and standards. Moreover, the Bidder undertakes to:
 - i) Ensure the entitlement of workers to wages, hours of work, safety and health and other prevailing conditions of work as established by national laws, rules and regulations; or Collective Bargaining Agreement (CBA) or arbitration award, if and when applicable.

In case there is a finding by the Procuring Entity or the Department of Labor and Employment (DOLE) of underpayment or non-payment of workers’ wages and wage-related benefits, the Bidder agrees that the performance security or portion of the contract amount shall be withheld in favor of the complaining workers pursuant to appropriate provisions of RA No. 12009, without prejudice to the institution of appropriate actions under the Labor Code, as amended, and other social legislations;
 - ii) Comply with Occupational Safety and Health Standards (OSHS) and correct deficiencies, if any.

In case of imminent danger, injury or death of the worker, the Bidder undertakes to suspend contract implementation pending clearance to resume from the DOLE Regional Office, in compliance with the Work Stoppage Order; and

- iii) Inform the workers of their conditions of work, labor clauses under the contract specifying wages, hours of work and other benefits under prevailing national laws, rules and regulations; or CBA or arbitration award, if and when applicable, through posting in two (2) conspicuous places in the establishment's premises.
- k) Ensured that it did not give or pay, directly or indirectly, any commission, amount, fee, or any form of consideration, pecuniary or otherwise, to any person or official, personnel or representative of the government in relation to any procurement project or activity;
- l) Examined all instructions, forms, terms, and specifications in the Bidding Documents;
- m) Determined and complied with all matters pertaining to the contract to be bid, including but not limited to: (i) the location and the nature of the contract, project, or work; (ii) climatic conditions; (iii) transportation facilities; (iv) nature and condition of the terrain, geological conditions at the site communication facilities, requirements, location and availability of construction aggregates and other materials, labor, water, electric power and access roads; and (v) other factors that may affect the cost, duration and execution or implementation of the contract, project, or work; and
- n) Ensured that all information in the Bidding Documents, including bid or supplemental bid bulletin(s) issued, are correct and consistent. The Procuring Entity shall not assume any responsibility regarding erroneous interpretations or conclusions by the prospective or eligible Bidder out of the data furnished by the Procuring Entity.

Failure to observe any of the above responsibilities shall be at the risk of the Bidder concerned;

6.4 The Bidder, by the act of submitting its bid, shall be deemed to have inspected the site, determined the general characteristics of the contract works and the conditions for this Project and examine all instructions, forms, terms, and project requirements in the Bidding Documents.

6.5 Further, the Bidder shall bear all costs associated with the preparation and submission of its bid, and the Procuring Entity shall in no case be responsible or liable for those costs, regardless of the conduct or outcome of the bidding process.

In case of failure of bidding, the Bidding Documents fee may be applied in the re-bidding for the same Project.

6.6 Furthermore, the Bidder should be aware that the Procuring Entity will accept bids only from those that have paid the applicable fee for the Bidding Documents at the office indicated in the Invitation to Bid.

7) **Origin of Goods and Services**

Unless otherwise indicated in the **BDS**, there is no restriction on the origin of Goods, or Contracting of Works or Services other than those prohibited by a decision of the United Nations Security Council taken under Chapter VII of the Charter of the United Nations.

8) **Subcontracts**

8.1 Unless otherwise specified in the **BDS**, the Bidder may subcontract portions of the Works to an extent as may be approved by the HoPE and as stated in the **BDS**. However, the subcontracted portion shall not exceed fifty (50%), or a different percentage of the ABC, on a per project basis, as approved by the GPPB.

8.2 Subcontracting of any portion of the Project shall not relieve the Bidder from any liability or obligation that may arise from the contract.

8.3 Subcontractors must meet the eligibility criteria as stated in the **BDS** and shall submit the same eligibility documents as the general contractor. Failure of a subcontractor to meet the eligibility criteria does not affect the eligibility of the general contractor for the procurement project. In such case, the portion intended to be subcontracted to the ineligible subcontractor shall be assumed by the general contractor.

8.4 Subcontracting arrangement, if allowed, including the time of submission of the eligibility documents of the subcontractor, shall be disclosed in the **BDS**.

B. Contents of Bidding Documents

9) **Pre-Bid Conference**

9.1 If so specified in the **BDS**, a pre-bid conference shall be held either at the Procuring Entity's physical address and/or online through videoconferencing, webcasting, or similar technology, or a combination thereof, on the date indicated therein, to clarify and address the Bidders' questions on the technical and financial components of this Project.

9.2 The pre-bid conference shall be held at least twelve (12) calendar days before the deadline for the submission of and receipt of bids, but not earlier than seven (7) calendar days from the posting of the invitation to bid and other bidding documents on the PhilGEPS website.

9.3 Bidders are highly encouraged to attend the pre-bid conference to fully understand the Procuring Entity's requirements. While non-attendance of the Bidder will in no way prejudice its bid, the Bidder is deemed to know any changes and/or amendments to the Bidding Documents, as may be provided in the Supplemental Bid Bulletin.

The proceedings of the pre-bid conference shall be recorded, and the corresponding minutes shall be prepared not later than five (5) calendar days after the pre-bid conference. The minutes shall be made available to prospective Bidders not later than five (5) days upon written request.

- 9.4 Decisions of the BAC amending any provision of the Bidding Documents shall be issued in writing through a Supplemental Bid Bulletin at least seven (7) calendar days before the deadline for the submission and receipt of bids.

10) Clarification and Amendment of Bidding Documents

- 10.1 Prospective bidders may request for clarification(s) on and/or interpretation of any part of the Bidding Documents. Such a request must be in writing and submitted to the BAC of the Procuring Entity at the address or electronic mail indicated in the **BDS** or through the electronic bidding facility of PhilGEPS, as may be applicable, at least ten (10) calendar days before the deadline set for the submission and receipt of Bids.
- 10.2 The BAC shall respond to the said request by issuing a Supplemental Bid Bulletin duly signed by the BAC Chairperson. It shall be made available to all those who have properly secured the Bidding Documents, at least seven (7) calendar days before the deadline for the submission and receipt of Bids.
- 10.3 Supplemental Bid Bulletins may also be issued upon the Procuring Entity's initiative for purposes of clarifying or modifying any provision of the Bidding Documents not later than seven (7) calendar days before the deadline for the submission and receipt of Bids. Any modification to the Bidding Documents shall be identified as an amendment.
- 10.4 Any Supplemental Bid Bulletin issued by the BAC shall also be posted on the PhilGEPS website, in any conspicuous place in the premises of the Procuring Entity, and on the website or social media platforms of the Procuring Entity, if available, or such other channels as may be authorized by the GPPB. It shall be the responsibility of all prospective bidders, including those who have properly secured the Bidding Documents, to inquire and secure Supplemental Bid Bulletins that may be issued by the BAC. However, Bidders who have submitted bids before the issuance of the Supplemental Bid Bulletin must be accordingly informed by the BAC, and be allowed to modify or withdraw their bids prior to the deadline for the submission and receipt of bids in accordance with ITB Clause 21.

C. Preparation of Bids

11) Language of Bids

The eligibility requirements or statements, the bids, and all other documents to be submitted to the BAC must be in English. If the eligibility requirements or statements, the bids, and all other documents submitted to the BAC are in foreign language other than English, it must be accompanied by a translation of the documents in English. The documents shall be translated by the relevant foreign government agency, the foreign government agency authorized to translate documents, or a registered translator in the foreign bidder's country. The Bidder shall cause the authentication of the translated documents and shall be authenticated by the appropriate Philippine foreign service establishment or post or the equivalent office having jurisdiction over the foreign bidder's affairs in the Philippines. However, for Contracting Parties to the Apostille Convention, the documents shall be authenticated through an apostille by the Competent Authority, as defined in Section 20.2.9.2 of the IRR, except for countries identified by the DFA that will still require legalization (red ribbon) by the relevant Embassy or Consulate. The English translation shall govern, for purposes of interpretation of the bid.

12) Documents Comprising the Bid: Technical and Financial Components

12.1 The first bid envelope shall contain the following technical documents, including the eligibility documents:

- a) PhilGEPS Certificate of Registration (Platinum Membership) in accordance with Section 20 of the IRR;
- b) PCAB License and Registration, in case of Joint Venture (JV);
- c) Statement of all its ongoing government and private contracts, including contracts awarded but not yet started, if any, whether similar or not similar in nature and complexity to the contract to be bid;
- d) Statement of the Bidder's SLCC, in accordance with **ITB** Clause 5.5.

The SLCC shall be supported by an Owner's Certificate of Final Acceptance issued by the project owner other than the Contractor, or a final rating of at least satisfactory in the CPES, or a similar performance and monitoring system. In case of contracts with the private sector, an equivalent document shall be submitted;

- e) NFCC computation in accordance with **ITB** Clause 5.6;
- f) Joint Venture Agreement (JVA), if applicable;
- g) Bid Security in the prescribed form and amount in accordance with **ITB** Clause 16, and validity period under **ITB** Clause 15;
- h) Project Requirements, which shall include the following:
 - i) Organizational chart of the personnel to be deployed for the procurement project to be bid;
 - ii) List of Contractor's personnel (e.g., Project Manager, Project Engineers, Materials Engineers, and Foremen), to be assigned to the procurement project to be bid, with their complete qualifications and experience data. These personnel must meet the required minimum years of experience set in the **BDS**;
 - iii) List of Contractor's major equipment units which are owned, leased, or under purchase agreements, supported by proof of ownership or certification of availability of equipment from the equipment lessor or vendor for the duration of the project, as the case may be, which must meet the minimum requirements for the contract set in the **BDS**; and
 - iv) Omnibus Sworn Statement in accordance with Section 54.3 of the IRR.

12.2 The second bid envelope shall contain the Financial Bid Form, which includes the bid prices and the bill of quantities, in accordance with **ITB** Clauses 13.1.

- 12.3 Whenever necessary, modifications may be made to the foregoing provisions specifically for major and specialized procurement to suit the particular needs of the Procuring Entity, subject to the approval of the GPPB.
- 12.4 All bids that exceed the ABC shall not be accepted. Unless otherwise indicated in the **BDS**, for foreign-funded procurement, the ABC shall be applied as the ceiling to bid prices provided the following conditions are met:
- a) Bidding Documents are obtainable free of charge on a freely accessible website. If payment of Bidding Documents is required by the Procuring Entity, payment could be made upon the submission of bids.
 - b) The Procuring Entity has procedures in place to ensure that the ABC is based on recent estimates made by the engineer or the responsible unit of the Procuring Entity and that the estimates are based on adequate detailed engineering and reflect the quality, supervision and risk, and inflationary factors, as well as prevailing market prices, associated with the types of works or goods to be procured.
 - c) The Procuring Entity has trained cost estimators on estimating prices and analyzing bid variances. In the case of Infrastructure Projects, the Procuring Entity must also have trained quantity surveyors.
 - d) The Procuring Entity has established a system to monitor and report bid prices relative to ABC and engineer's or Procuring Entity's estimate.
 - e) The Procuring Entity has established a monitoring and evaluation system for contract implementation to provide feedback on actual total costs of goods and works.

However, the GoP and the foreign government, or foreign or international financing institutions may agree to waive the foregoing conditions.

13) Bid Prices

- 13.1 The contract shall be for the whole Works, as described in the Bidding Documents, based on the priced Bill of Quantities submitted by the Bidder.
- 13.2 The Bidder shall fill in rates and prices for all items of the Works described in the Bill of Quantities. In case partial bids are allowed in the ITB, bids not addressing or providing all of the required items in the Bidding Documents including, where applicable, the Bill of Quantities, shall be considered non-responsive and shall be automatically disqualified. In this regard, where a required item is provided, but no price is indicated, the same shall be considered as non-responsive, but specifying a zero (0) or a dash (-) for the said item would mean that it is being offered for free to the Government, except those required by law or regulations to be provided for.
- 13.3 For the given scope of work in the contract as awarded, all bid prices shall be considered as fixed prices, and therefore not subject to price escalation during contract implementation, except under extraordinary circumstances as specified in GCC Clause 45.

14) Bid Currencies

- 14.1 All bid prices shall be quoted in Philippine Peso unless otherwise provided in the **BDS**. However, for purposes of bid evaluation, bids denominated in foreign currencies shall be converted to Philippine currency based on the exchange rate as published in the BSP Daily Reference Exchange Rate Bulletin on the day of the bid opening.³
- 14.2 If so allowed in accordance with **ITB** Clause 14.1, the Procuring Entity, for purposes of bid evaluation and comparing the bid prices, will convert the currencies in which the bid price is expressed to Philippine Peso at the foreign exchange rates.
- 14.3 Unless otherwise specified in the **BDS**, payment of the contract price shall be made in Philippine Peso.

15) Bid Validity

- 15.1 Bids shall remain valid for the period specified in the **BDS** which shall not exceed one hundred twenty (120) calendar days from the date of the opening of bids.
- 15.2 Should it become necessary to extend the validity of the bids and the bid securities beyond one hundred twenty (120) calendar days, the Procuring Entity concerned shall request in writing all those who submitted bids for such extension before the expiration date therefor. Bidders, however, shall have the right to refuse to grant such extension without forfeiting their Bid Security.

16) Bid Security

- 16.1 The Bidder, at its option, shall submit a Bid Security in the form and amount as stated in the **BDS**, which may include the following:

Form of Bid Security	Amount of Bid Security (Not less than the required Percentage of the ABC)
(a) Cash or cashier's/manager's check issued by a bank. <i>For biddings conducted by LGUs, the Cashier's or Manager's check may be issued by other banks certified by the BSP as authorized to issue such financial instrument.</i>	Two percent (2%)
(b) Bank draft/guarantee or irrevocable Letter of Credit issued by a bank; Provided, however, that it shall be confirmed or authenticated by a local bank, if issued by a foreign bank.	Five percent (5%)

³ RA No. 8183 or "An Act to Assure Uniform Value to Philippine Coin and Currency."

<i>For biddings conducted by LGUs, the Bank Draft/ Guarantee, or irrevocable letter of credit may be issued by other banks certified by the BSP as authorized to issue such financial instrument.</i>	
(c) Surety bond callable upon demand issued by a surety or insurance company duly certified by the Insurance on as authorized to issue such security.	Five percent (5%)
(d) Bid Securing Declaration	Not Applicable

The Bid Security shall be denominated in Philippine Peso and posted in favor of the Procuring Entity.

- 16.2 The Bid Security should be valid for the period specified in the **BDS**. Any bid not accompanied by an acceptable Bid Security shall be considered as non-responsive and rejected by the Procuring Entity.
- 16.3 In no case shall the Bid Security be returned later than the expiration of the bid validity period indicated in the Bidding Documents, unless it has been extended in accordance with Section 57.2 of the IRR. In case the bidder is required to extend its bid validity, the bidder may, at its discretion, substitute a Bid Securing Declaration for the extended period as a replacement of its Bid Security; Provided, that the option to substitute is indicated in the **BDS**.
- 16.4 Upon signing and execution of the contract, pursuant to **ITB** Clause 29, and the posting of the performance security pursuant to **ITB** Clause 30, the Bid Security of the successful Bidder's Bid Security will be discharged, but in no case later than its validity period as indicated in **ITB** Clause 15.
- 16.5 The Bid Security may be forfeited based on any of the following grounds, as provided under Rule VIII, X, XI, and XXI of the IRR:
- a) If a Bidder:
 - i) With the Lowest Calculated Responsive Bid (LCRB), Most Economically Advantageous Responsive Bid (MEARB), Most Advantageous Responsive Bid (MARB), Single Calculated and Responsive Bid (SCRB), Single Economically Advantageous Responsive Bid (SEARB), or Single Advantageous Responsive Bid (SARB) withdraws, fails, refuses or is unable to: (i) submit the documents required under Section 66.5 of the IRR; (ii) enter into contract with the Procuring Entity; or (iii) post the required performance security within the period stipulated in the IRR and in accordance with **ITB** Clause 30;
 - ii) Causes the delay, without justifiable cause, of the screening for eligibility, opening of bids, evaluation and post evaluation of Bids, and awarding of contracts;

- iii) Refuses to clarify or validate in writing its bid during post-qualification within a period of seven (7) calendar days from receipt of the request for clarification;
- iv) Withdraws a bid, or refuses to accept an award, or refuses or fails to enter into contract with the Procuring Entity without justifiable cause, after the approval of the HoPE for having been the declared LCRB or MEARB, as the case may be;
- v) Refuses or fails to furnish performance security within the prescribed time;
- vi) Commits of three (3) or more of any of the acts imposed with suspension, as provided under Section 99 of the IRR;
- vii) Uses force, fraudulent machinations, coercion, undue influence or pressure on any member of the BAC or any officer or employee of the Procuring Entity to take a particular action for its own favor or gain, or to the advantage of a particular bidder;
- viii) Colludes with one (1) or more bidders and submitting different bids as if they were bona fide, when they knew that one or more of them was so much higher than the other that it could not be honestly accepted and that the contract will surely be awarded to the pre-arranged lowest bid;
- ix) Maliciously submits different bids through two (2) or more persons, corporations, partnerships, or any other business entity in which it has interest, to create the appearance of competition that does not in fact exist so as to be declared as the winning bidder;
- x) Enters into an agreement with other bidder/s which call upon one to refrain from bidding for procurement contracts, or which call for withdrawal of bids already submitted, or which are otherwise intended to secure an undue advantage to any of the bidders;
- xi) Fails to faithfully disclose its relationship, regardless of the time of its discovery, with the HoPE, members of the BAC, the TWG, and the BAC Secretariat, the head of the PMO or the End-User or Implementing Unit, and the project consultants of the Procuring Entity, or of the procurement agent, whichever is applicable, by consanguinity or affinity up to the third civil degree pursuant to Section 81 of the IRR;
- xii) Submits beneficial ownership information containing false entries;
- xiii) Allows the use of one's name or uses the name of another for purposes of public bidding;
- xiv) Submits eligibility requirements and bids containing false information or falsified documents or the concealment of such

information that will materially alter the outcome of eligibility screening or any stage of the procurement;

- xv) Accesses the contents of any Bid submitted to the Procuring Entity before the opening of bids, without authorization;
 - xvi) Has any documented attempt to unduly influence the outcome of the bidding;
 - xv) Employs schemes which stifle or suppress any procurement activity; or
 - xvi) Commits a third offense imposed with blacklisting under the Act by the same Procuring Entity, or a combination of three (3) violations imposed with blacklisting by the Procuring Entity and other Procuring Entities, as posted on the GPPB portal;
- b) If a Winning Bidder:
- i) Conducts poor performance or unsatisfactory quality and/or progress of work. Poor performance shall be as follows:
 - i.i) Negative slippage of fifteen percent (15%) and above within the critical path of the project due entirely to the fault or negligence of the winning bidder; or
 - i.ii) Non-compliance of the materials and workmanship with the approved specifications arising from the fault or negligence of the winning bidder.
 - ii) In case it is determined prima facie that the winning bidder has engaged, before or during the implementation of the contract, in the following unlawful deeds and behaviors relative to contract acquisition and implementation:
 - ii.i) Corrupt, fraudulent, collusive and coercive practices;
 - ii.ii) Drawing up or using forged documents; or
 - ii.iii) Using adulterated materials, means or methods, or engaging in production contrary to rules of science or trade.
 - iii) Assigns or subcontracts the contract or any part thereof or substituting key personnel named in the proposal without prior written approval by the Procuring Entity;
 - iv) Willfully or deliberately abandons or does not perform the project or contract by the winning bidder resulting in substantial breach thereof without lawful and/or just cause;
 - v) Has its contract terminated due to its default or unlawful acts; or
 - vi) Fails to comply with the provision on warranty that requires to repair any noted defect or damage to the Infrastructure Project

due to the use of materials of inferior quality within ninety (90) calendar days from the issuance of the order by the HoPE to undertake such repairs.

17) Format and Signing of Bids

- 17.1 Bidders shall submit their bids through their duly authorized representative using the appropriate forms provided in Section IX. Philippine Bidding Documents Related Forms on or before the deadline specified in the **ITB** Clause 19 in two (2) separate sealed bid envelopes which shall be submitted simultaneously, whether through manual or online submission. The first shall contain the technical component of the bid, including the eligibility requirements under **ITB** Clause 12, and the second shall contain the financial component of the bid.
- 17.2 Forms as mentioned in **ITB** Clause 17.1 must be completed without any alterations to their format. No substitute form shall be accepted.
- 17.3 Each and every page of the Bid Form, including the Bill of Quantities, under Section IX hereof, shall be signed by the duly authorized representative/s of the Bidder. Failure to do so shall be a ground for the rejection of the bid.
- 17.4 Any insertions, erasures, or overwriting shall be valid only if they are signed or initialed by the duly authorized representative/s of the Bidder.

18) Sealing and Marking of Bids

- 18.1 Bidders shall enclose their technical documents described in **ITB** Clause 12 in one sealed envelope marked "TECHNICAL COMPONENT," and the financial component in another sealed envelope marked "FINANCIAL COMPONENT," sealing them all in an outer envelope marked "BID."
- 18.2 The Bid shall be typed or written in ink and shall be signed by the Bidder or its duly authorized representative/s.
- 18.3 All envelopes shall:
 - a) contain the name of the contract to be bid in capital letters;
 - b) bear the name and address of the Bidder in capital letters;
 - c) be addressed to the Procuring Entity's BAC in accordance with **ITB** Clause 18.1;
 - d) bear the specific identification of this bidding process indicated in the **ITB** Clause 1.1; and
 - e) bear a warning "DO NOT OPEN BEFORE..." the date and time for the opening of bids, in accordance with **ITB** Clause 19.
- 18.4 For manually submitted bid envelopes that are not properly sealed and marked, as required in the Bidding Documents, the same shall be accepted; Provided, That the bidder or its duly authorized representative shall acknowledge such condition of the bid as submitted. On the other hand, unsealed or unmarked

bid envelopes, or bids that cannot be opened or corrupted in case of online submission, shall be rejected.

The BAC shall assume no responsibility for misplaced or lost contents of the improperly sealed or marked bid, or for its premature opening.

D. Submission and Opening of Bids

19) Deadline for Submission of Bids

Bids must be received by the Procuring Entity's BAC at the address indicated in the **Invitation to Bid**, or through the e-bidding facility of the PhilGEPS, on or before the date and time indicated in the **BDS**.

20) Late Bids

Bids, including the eligibility requirements, submitted after the deadline shall be rejected by the BAC. The BAC shall record in the Minutes of the Meeting the submission and opening of bids, the Bidder's name, its representative, and the time the late bid was submitted.

21) Modification and Withdrawal of Bids

21.1 Bidders may modify their bids before the deadline for the submission and receipt of bids.

a) For manual submission and receipt of bids, the Bidders shall not be allowed to retrieve their original bid, but shall only be allowed to submit the bid modification by sending another bid, equally sealed, properly identified, linked to its original bid, and marked as a "modification," thereof, and stamped "received" by the BAC. Bid modifications received after the applicable deadline shall not be considered and shall be returned to the bidder unopened.

b) For online submission of bids, the Bidders shall not be allowed to retrieve their original Bid, but shall only be allowed to submit the bid modification, send another Bid equally secured, properly identified labelled as a "modification" of the one previously submitted. The time indicated in the latest bid receipt page generated shall be the official time of submission. Bids modification submitted after the applicable deadline shall not be accepted.

21.2 Bidders may withdraw their bids in writing before the deadline for submission and receipt of bids. Withdrawal of bids after the applicable deadline shall be subject to appropriate sanctions as prescribed in the IRR.

Bidders may also express their intention not to participate in the bidding in writing, which should be received by the BAC before the deadline for submission and receipt of bids. Bidders that withdraw their bids shall no longer be allowed to submit another bid for the same contract, directly or indirectly.

21.3 No bid may be modified after the deadline for submission and receipt of bids. Further, no bid may be withdrawn in the interval between the deadline for submission and receipt of bids, and the expiration of bid validity specified by the Bidder in the Financial Bid Form. Withdrawal of bid during this interval shall

result in the forfeiture of the Bidder's Bid Security pursuant to **ITB** Clause 16.5, and the imposition of administrative sanctions as prescribed by RA No. 12009 and without prejudice to the imposition of civil and criminal sanctions as provided under applicable laws.

Alternative Bids shall be rejected. For this purpose, Alternative Bid shall pertain to an offer made by a bidder in addition or as a substitute to its original bid, which may be included as part of its original bid or submitted separately. A bid with options shall likewise be considered an Alternative Bid regardless of whether said bid proposal is contained in a single envelope or submitted in two (2) or more separate bid envelopes.

Bidders shall submit offers that comply with the requirements of the Bidding Documents, including the basic technical design as indicated in the drawings and specifications. Unless there is a value engineering clause in the **BDS**, alternative bids shall not be accepted.

Each Bidder shall submit only one Bid, either individually or as a partner in a JV. A Bidder who submits or participates in more than one bid (other than as a subcontractor if a subcontractor is permitted to participate in more than one bid) will cause all the proposals with the Bidder's participation to be disqualified. This shall be without prejudice to any applicable criminal, civil and administrative penalties that may be imposed upon the persons and entities concerned.

22) Opening and Preliminary Examination of Bids

- 22.1 The BAC shall open the bids in public, immediately after the deadline for submission and receipt of bids, as specified in the **BDS**. In case the Bids cannot be opened as scheduled due to justifiable reasons, the BAC shall take custody of the submitted Bids and reschedule the opening of Bids on the next working day or at the soonest possible time, through the issuance of a Notice of Postponement to be posted on the PhilGEPS website and the website of the Procuring Entity concerned.
- 22.2 The manner of opening of the bids for Infrastructure Projects shall depend on the award criterion to be adopted, as follows:
 - a) For LCRB and MEARB, the BAC shall open the technical and financial proposals on the same day; and
 - b) For MARB, only the technical proposals shall be opened while the financial proposals shall remain unopened and shall be kept securely by the BAC until the specified time of their opening as indicated in the **BDS**. Only the financial proposals of the bidders who have met the highest technical score for MAB shall be opened.
- 22.3 The Procuring Entity shall prepare the minutes of the proceedings of the bid opening that shall include, as a minimum: (a) names of Bidders, their bid price (per lot, if applicable, and/or including discount, if any), bid security, findings of preliminary examination, and whether there is a withdrawal or modification; and (b) attendance sheet. The BAC members shall sign the abstract of bids as read.
- 22.4 The Bidders or their duly authorized representatives may attend the opening of bids. The BAC shall ensure the integrity, security, and confidentiality of all

submitted bids. The Abstract of bids, as read, and the minutes of the bid opening shall be made available to the public, upon written request and payment of a specified fee to recover the cost of materials.

- 22.5 To ensure transparency and accurate representation of the bid submission, the BAC Secretariat shall notify in writing all bidders whose bids it has received through mail at its PhilGEPS-registered physical address or official e-mail address. The said notice shall be issued within seven (7) calendar days from the date of the bid opening.

E. Evaluation and Comparison of Bids

23) Process to be Confidential

- 23.1 Members of the BAC, its staff and personnel, Secretariat, and TWG, as well as Observers, are prohibited from making or accepting any communication with any bidder regarding the evaluation of their bids until the issuance of the Notice of Award, unless otherwise allowed in the case of **ITB** Clause 24.
- 23.2 Any effort by a Bidder to influence the Procuring Entity in the Procuring Entity's decision in respect of bid evaluation, bid comparison or contract award will result in the rejection of the bid.

24) Clarification of Bids

To assist in the evaluation, comparison, and post-qualification of the bids, the Procuring Entity may ask in writing any Bidder for a clarification of its bid. All responses to requests for clarification shall be in writing. Any clarification submitted by a Bidder in respect to its bid that is not in response to the request of the Procuring Entity shall not be considered.

25) Detailed Evaluation and Comparison of Bids

- 25.1 The Procuring Entity's evaluation of bids shall be based on the bid price quoted in the Bid Form, which includes the Bill of Quantities.
- 25.2 The Procuring Entity will undertake the detailed evaluation and comparison of the bids which have passed the opening and preliminary examination of bids, pursuant to **ITB** Clause 22, to determine the Lowest Calculated Bid (LCB), Most Economically Advantageous Bid (MEAB), and Most Advantageous Bid (MAB).
- 25.3 The award criterion shall be determined as follows:
- a) For LCB:
 - i) The detailed evaluation of the financial component of the bids, to establish the correct calculated prices of the bids; and
 - ii) The ranking of the total bid prices as so calculated from the lowest to highest, where the bid with the lowest price shall be identified as the LCB.
 - b) For MEAB, the BAC shall evaluate the quality and price proposals to determine the MEAB using the following steps:

- i) The quality proposal together with the price proposal shall be considered in the evaluation of bids. The quality proposals shall be evaluated first using the criteria in the **BDS**. The price proposals of the bids that meet the minimum quality score shall then be opened.
- ii) The price and quality proposals shall be given corresponding weights with the price proposal given a minimum weight of fifteen percent (15%) up to a maximum of forty percent (40%). The weight of the quality criteria shall be adjusted accordingly such that their total weight in percent together with the weight given to the price proposal shall be equal to one hundred percent (100%).
- iii) To further promote green public procurement, the sustainability of materials or structures with green specifications shall be given greater weight in the evaluation of bids. As approved by the BAC, the exact weights shall be indicated in the **BDS**. The BAC shall rank the bidders in descending order based on the combined numerical ratings of their quality and price proposals. The bidder with the best overall score using the quality-price ratio shall be referred to as the MEAB.
- iv) The HoPE shall approve or disapprove the recommendations of the BAC within two (2) calendar days after receipt of the results of the evaluation from the BAC.

The quality component shall be assessed on the basis of criteria with corresponding numerical weights indicated in the **BDS**, which may include qualitative, environmental, or social aspects linked to the subject matter of the contract. These may include any or a combination of the following:

- a) Quality and technical merit, including technical competence and a credible track record;
- b) Aesthetic and functional design and characteristics;
- c) Approach and methodology;
- d) Accessibility;
- e) Tools and equipment;
- f) Social, environmental, economic, and innovative characteristics;
- g) Organization, qualification, and experience of employees or staff assigned to perform the contract;
- h) Ongoing contracts and work commitments; or
- i) Other relevant criteria in relation to the subject Infrastructure Projects to be procured.

c) For MAB

- i) The BAC shall evaluate the quality proposals to determine the MAB using the quality components. The quality components shall be

assessed on the basis of the criteria with corresponding numerical weights indicated in the **BDS** to determine the bidder with the highest technical rating.

- ii) The second bid envelope of the bidder obtaining the highest technical rating shall be opened. If the financial proposal is equal to or lower than the ABC, the bid shall be accepted and determined as the MAB; otherwise, the same shall be rejected and the bidder will be disqualified.

25.4 In order to eliminate bias in evaluating the quality proposals, it is recommended that the highest and lowest scores for each bidder for each criterion shall not be considered in determining the average scores of the bidders, except when the evaluation is conducted in a collegial manner.

25.5 The BAC shall immediately conduct a detailed evaluation of all bids using non-discretionary criteria in considering the following:

- a) Completeness of the bid. Unless the **BDS** allows partial bids, bids not addressing or providing all of the required items in the BDS shall be considered non-responsive and, thus, automatically disqualified.

However, when no price or a zero (0) or a dash (-) is indicated in a required item in the bid form, the same shall be construed that it is being offered for free to the Government, except those required by law or regulations to be provided for; and

- b) Arithmetical corrections. The BAC shall consider computational errors and omissions to enable proper comparison of all eligible bids. It may also consider bid correction if expressly allowed in the **BDS**. Any adjustment shall be calculated in monetary terms to determine the calculated prices.

25.6 Based on the detailed evaluation of bids, those that comply with the above-mentioned requirements shall be ranked in the ascending order of their total calculated bid prices, as evaluated and corrected for computational errors, discounts and other modifications, to identify the LCB, MEAB, or MAB. Total calculated bid prices, as evaluated and corrected for computational errors, discounts and other modifications, which exceed the ABC shall not be considered, unless otherwise indicated in the **BDS**.

25.7 The BAC shall evaluate all bids on an equal footing to ensure fair and competitive bid comparison. For this purpose, all bidders shall be required to include in their bids the cost of all taxes, such as, but not limited to, value-added tax (VAT), income tax, local taxes, and other fiscal levies and duties. Such bids, including said taxes, shall be the basis for the bid evaluation and comparison.

25.8 If so indicated pursuant to **ITB** Clause 1.1, bids may be submitted for individual lots, or for any combination thereof, provided that all bids and combinations of bids shall be received by the same deadline and opened and evaluated simultaneously so as to determine the bid or combination of bids offering the lowest calculated cost to the Procuring Entity. Bid prices quoted shall correspond to all of the requirements specified for each lot. Bid Security as required by **ITB** Clause 16 shall be submitted for each contract (lot) separately. The basis for evaluation of lots is specified in **BDS** Clause 25.5 (a).

26) Post - Qualification

- 26.1 The BAC shall determine to its satisfaction whether the Bidder that is evaluated as having submitted the LCB, MEAB, or MAB, as the case may be, complies with and is responsive to all the requirements and conditions specified in **ITB** Clauses 5 and 12. The Bidder, within a non-extendible period of five (5) calendar days from receipt of notice from the BAC that it submitted the LCB, MEAB, or MAB, shall submit all the eligibility documents supporting its PhilGEPS Certificate of Registration (Platinum Membership), its latest income and business tax returns filed for the preceding quarter which should not be earlier than two (2) quarters from the date of submission and receipt of bid, and other appropriate licenses and permits required by law and stated in the **BDS**.
- 26.2 Failure to submit any of the post-qualification requirements on time, or a finding against the veracity thereof, shall disqualify the Bidder for award; Provided, that in the event that a finding against the veracity of any of the documents submitted is made, it shall cause the forfeiture of the Bid Security.
- 26.3 The determination shall be based upon an examination of the documentary evidence of the Bidder's qualifications submitted pursuant to **ITB** Clause 12, as well as other information as the Procuring Entity deems necessary and appropriate, using a non-discretionary "pass/fail" criterion, which shall be completed within a period of twelve (12) calendar days.
- 26.4 If the BAC determines that the bidder with the LCB, MEAB, or MAB passes all the criteria for post-qualification, it shall declare the said bid as the LCRB, MEARB, MARB, SCB, SEAB, or Single Advantageous Bid (SAB) and recommend to the HoPE the award of contract to the said bidder at its submitted bid price or its calculated bid price, whichever is lower or, in the case of quality-based evaluation procedure, submitted bid price or its negotiated price, whichever is lower.
- If, however, the BAC determines that the bidder with the LCB, MEAB, MAB, SCB, SEAB, or SAB fails to meet the post-qualification criteria, it shall immediately notify the Bidder in writing of its post-disqualification and the grounds for such determination.⁴
- 26.5 Immediately after the BAC has notified the first bidder of its post-disqualification, and notwithstanding any pending request for reconsideration thereof, the BAC shall initiate and complete the same post-qualification process on the bidder with the second LCB, MEAB, or MAB. If the second bidder passes the post-qualification and provided that the request for reconsideration of the first bidder has been denied, the second bidder shall be post-qualified as the bidder with the LCB, MEAB, or MAB.
- 26.6 If the second bidder, however, fails the post-qualification, the procedure for post-qualification shall be repeated for the bidder with the next LCB, MEAB, or MAB and so on, until the LCRB, MEARB, or MARB, as the case may be, is determined for award, subject to the procedure of Notice and Execution of Award.

⁴ Sec 63.5 of the IRR.

- 26.7 Within a period not exceeding ten (10) calendar days from the determination by the BAC of the LCRB, MEARB, MARB, SCRIB, SEARB, or SARB and the recommendation to award the contract, the HoPE or its duly authorized representative shall approve or disapprove the said recommendation.
- 26.8 In case of approval, the HoPE or its duly authorized representative shall immediately issue the Notice of Award to the bidder with the LCRB, MEARB, MARB, SCRIB, SEARB, or SARB, as the case may be.

In the event that the approving authority shall disapprove the resolution on the award of the contract, such disapproval shall be based only on valid, reasonable, and justifiable grounds as enumerated under Section 70 of the IRR to be expressed in writing. A copy of the decision disapproving the resolution shall be furnished to the BAC and the bidder.

27) Reservation Clause

- 27.1 Notwithstanding the eligibility or post-qualification of a bidder and without incurring any liability, the HoPE or its duly authorized representative at any stage of the procurement, reserves the right to review its qualifications, reject any and all bids, declare a failure of bidding or not award the contract in the following situations:
- a) If it has reasonable grounds to believe that a misrepresentation has been made by the said bidder; or
 - b) If it has reasonable grounds to believe that there has been a change in the bidder's capability to undertake the project from the time it submitted its eligibility requirements.

Should such review uncover any misrepresentation made in the eligibility and bidding requirements, statements or documents, or any changes in the situation of the Bidder which will adversely affect its capability to undertake the Project so that it no longer meets the prescribed eligibility or bid evaluation criteria, the Procuring Entity shall consider the said Bidder as ineligible and disqualify it from participating further in the bidding process or being awarded the contract.

- 27.2 Based on the following grounds, the HoPE or its duly authorized representative reserves the right to reject any and all Bids, declare a Failure of Bidding at any time prior to the contract award, or not to award the contract, without thereby incurring any liability, and make no assurance that a contract shall be entered into as a result of the bidding:
- a) If there is *prima facie* evidence of collusion between appropriate public officers or employees of the Procuring Entity, or between the BAC and any of the bidders, or if the collusion is between or among the bidders themselves, or between a bidder and a third party, including any act which restricts, suppresses or nullifies or tends to restrict, suppress or nullify competition or influences or tends to influence the bidding process;
 - b) If the BAC is found to have failed in complying with the applicable law or in following the prescribed bidding procedures; or

- c) If there are any justifiable and reasonable ground where the award of the contract will not redound to the benefit of the government, in instances where (i) the physical and economic conditions have significantly changed so as to render the project no longer economically, financially or technically feasible as determined by the HoPE; (ii) the Project is no longer necessary as determined by the HoPE; and (iii) the source of funds for the Project has been withheld or reduced through no fault of the Procuring Entity.

F. Award of Contract

28) Contract Award

- 28.1 Subject to **ITB** Clause 26, the HoPE or its duly authorized representative shall award the contract to the Bidder whose bid has been determined to be the LCRB, MEARB, MARB, SCRB, SEARB, or SARB, as the case may be.
- 28.2 Prior to the expiration of the period of bid validity, the Procuring Entity shall notify the winning Bidder in writing that its bid has been accepted, through a Notice of Award duly received by the Bidder or its representative personally or by registered mail or electronically, receipt of which must be confirmed in writing within two (2) days by the Bidder with the LCRB, MEARB, MARB, SCRB, SEARB, or SARB, as applicable, and submitted personally or sent by registered mail or electronically to the Procuring Entity.
- 28.3 Within ten (10) calendar days from receipt by the winning bidder of the Notice of Award, the following conditions should be complied with before the contract may be awarded:
 - a) Submission of the following documents:
 - i) Valid JVA, if applicable;
 - ii) The SEC Certificate of Registration of the foreign corporation, if applicable; or
 - iii) Valid PCAB license and registration for the type and cost of the Project for foreign bidders when the Treaty or International or Executive Agreement expressly allows submission of such license and registration as a pre-condition to the Notice of Award.
 - b) Posting of the performance security in accordance with **ITB** Clause 30; and
 - c) Signing of the contract as provided in **ITB** Clause 29.

29) Signing of the Contract

- 29.1 Within ten (10) calendar days from receipt of the Notice of Award, the winning Bidder shall post the required performance security, sign and date the contract, and return it to the Procuring Entity.
- 29.2 The Procuring Entity shall enter into a contract with the successful Bidder within the same ten (10) calendar day period provided that all the documentary requirements are complied with.
- 29.3 The following documents shall form part of the contract:
- a) Contract Agreement;
 - b) Bidding Documents;
 - c) Winning Bidder's bid, including the technical and financial proposals, and all other documents/statements submitted (e.g., Bidder's response to request for clarifications on the bid), including corrections to the bid, if any, resulting from the Procuring Entity's bid evaluation;
 - d) Performance Security;
 - e) Notice of Award of Contract; and
 - f) Other contract documents that may be required by existing laws and/or specified in the **BDS**.

30) Performance Security

- 30.1 To guarantee the faithful performance by the winning bidder of its obligations under the contract, it shall post a performance security prior to the signing of the contract. Furthermore, the successful bidder shall be required to update the performance security posted before to the issuance of a variation order, if any.
- 30.2 Sectors enumerated under Section 76.1⁵ of the IRR may be allowed to post Performance Securing Declaration (PSD) as specified in the **BDS**.
- 30.3 The performance security shall be in a form selected by the Procuring Entity in the amount indicated in the **BDS**, which shall not be less than the percentage of the total contract price in accordance with the following price schedule:

⁵ Section 76.1. *The GPPB, once data is available from relevant agencies, shall maintain a registry of entities belonging to the following sectors:*

- a) Farmers as certified by the Department of Agriculture (DA);
- b) Fisherfolk as certified by the Bureau of Fisheries and Aquatic Resources (BFAR);
- c) Persons with disabilities as certified by the National Council for Disability Affairs (NCDA) pursuant to RA No. 7277, otherwise known as the Magna Carta for Disabled Persons, as amended;
- d) Solo parents as certified by the Department of Social Welfare and Development (DSWD); e) Microenterprises and social enterprises as certified by the MSMED Council;
- f) Startups, spin-offs, and other forms of entity involved in science, technology, and innovation activities as certified by the DTI, DICT, NIC or the Department of Science and Technology (DOST), as may be applicable;
- g) Cooperatives duly registered with the CDA pursuant to RA No. 6938, otherwise known as the Cooperative Code of the Philippines, as amended; and
- h) Other relevant sectors as may be determined by the GPPB to ensure inclusivity and diversity in the procurement process.

Form of Performance Security	Amount of Performance Security (Not less than the Percentage of the Total Contract Price)
a) Cash or Cashier's or Manager's check issued by a bank. <i>For biddings conducted by LGUs, the cashier's or manager's check may be issued by other banks certified by the BSP as authorized to issue such financial instrument.</i>	Ten percent (10%)
b) Bank draft or guarantee or irrevocable Letter of Credit issued by a local bank. If issued by a foreign bank, it shall be confirmed or authenticated by a local bank.	
c) Surety bond callable upon demand issued by a surety or insurance company duly certified by the IC as authorized to issue such security.	Thirty Percent (30%)

30.4 The performance security shall be denominated in Philippine Peso and posted in favor of the Procuring Entity, which shall be forfeited in the event it is established that the winning bidder is in default in any of its obligations under the contract.

31) Notice to Proceed

The Procuring Entity shall issue the Notice to Proceed to the winning Bidder not later than three (3) calendar days from the date of approval of the contract by the appropriate signatories. All notices called for by the terms of the contract shall be effective only at the time of receipt thereof by the successful Bidder.

32) Protest Mechanism

Decisions of the BAC in all stages of procurement may be protested to the HoPE in accordance with Section 83 of the IRR.

Section III. Bid Data Sheet

Bid Data Sheet

ITB Clause	
1.1	<p>The Procuring Entity is Bureau of Corrections</p> <p>The Project title is Design and Build of BUCOR Regional Facility One (1) Unit 3-Storey Type B Dormitory- Phase 5 with Project Identification Number 2026-010</p>
2	<p>The Funding Source is:</p> <p>2.1 The GOP through the source of funding as indicated below for SARO-BMB-D-25-0017303 dated November 27, 2025 in the amount of Three Hundred Million Pesos Only (P300,000,000.00).</p> <p>2.2 The source of funding is:</p> <p style="text-align: center;">NGA, the General Appropriations Act or Special Appropriations.</p>
3.1	No further instructions.
5.2	Bidding is restricted to eligible bidders as defined in ITB Clause 5.2.
5.4	<p>Contracts similar to the Project shall be those described as follows:</p> <p>Architectural, engineering design, detailed engineering requirements and construction of building with concreting works.</p>
7	No further instructions.
8.1	"Subcontracting is allowed."
8.3	<p>Technical Documents to be submitted by the Subcontractor:</p> <ol style="list-style-type: none"> 1. PhilGEPS Certificate of Registration (Platinum Membership) in accordance with Section 20 of the IRR. 2. Latest income and business tax returns filed for the preceding quarter which should not be earlier than two (2) quarters from the date of submission and receipt of bid. 3. Valid and Current Registration Certificate (SEC Certificate of Registration for Corporation or DTI Certificate of Registration for Sole Proprietorship or CDA Certificate of Registration for Cooperative). 4. Statement of all its ongoing government and private contracts. 5. Statement of Completed Contracts within the last four (4) years.

	<p>6. Valid and Current Mayor's or Business Permit.</p> <p>7. Valid and Current Tax Clearance.</p> <p>8. Valid and Current PCAB License and Registration.</p> <p>9. Audited Financial Statement.</p>
8.4	<p>The Subcontractor shall not exceed fifty (50%) for the subcontracted portion of the contract. <u>The subcontractor shall submit the eligibility documents during the submission of post qualification documents.</u></p> <p>In the event that a Subcontractor is post disqualified, or for whatever valid and justifiable reason during the contract implementation, the General Contractor may later request to replace the subcontractor. The General Contractor shall submit the proposed new Subcontractor for approval of the HoPE, upon recommendation of the end-user or implementing unit. The proposed subcontractor must meet the same eligibility criteria of the General Contractor.</p>
9.1	<p>The Procuring Entity will hold a pre-bid conference for this Project on 22 April 2026 (1000H) at BAC Conference Room, National Headquarters, NBP Reservation, Poblacion, Muntinlupa City.</p>
10.1	<p>The Procuring Entity's address is:</p> <p>Bureau of Corrections, National Headquarters, NBP Reservation, Poblacion, Muntinlupa City.</p> <p>CCSUPT MELENCIO S FAUSTINO Chairman, Bids and Awards Committee</p> <p>Tel # 02-8809-8587/02-8478-0907/02-8659-0833</p> <p>bacsec2022@gmail.com</p>
12.1(h)(ii)	<p>The minimum work experience requirements for key personnel are the following:</p> <p><u>For Design</u></p> <p>The key professionals and the respective qualifications of the DESIGN PERSONNEL shall be as follows:</p> <p>Principal Architect</p> <p>The Principal Architect must be duly-licensed with at least ten (10) years' experience in the design of residential, government offices or institutional facilities, and shall preferably be knowledgeable in the application of rapid construction technologies.</p> <p>Structural Engineer</p> <p>The Structural Engineer must be a duly-licensed Civil Engineer with at least ten (10) years' experience in structural design, including the</p>

design of vertical structures such as buildings and towers, and shall preferably be knowledgeable in the application of rapid construction technologies.

Professional Electrical Engineer

The Electrical Engineer must be a registered Professional Electrical Engineer with at least ten (10) years' experience in the design of lighting, power distribution, communication systems (specifically structured and local area network cabling, PABX), building management systems and preferably knowledgeable in developments in emergent efficient lighting technologies and energy management.

Professional Mechanical Engineer

The Mechanical Engineer must be a Professional Mechanical Engineer with at least ten (10) years in HVAC and fire Protection systems and preferably knowledgeable in emergent, alternative energy- efficient HVAC technologies.

Professional Electronics and Communications Engineer

The Electronics and Communications Engineer must be Professional Electronics and Communications Engineer with at least ten (10) years' experience in the design of communications systems, fire detection and alarm system and preferably knowledgeable in the application of building automation and surveillance systems.

Sanitary Engineer

The Sanitary Engineer must be duly-licensed with at least ten (10) years' experience in the design of building water supply and distribution, plumbing, and preferably knowledgeable in waste water management/treatment, and emergent, alternative effluent collection and treatment system.

The DESIGN & BUILD CONTRACTOR may, as needed and at its own expense, add additional professionals and/or support personnel for the optimal performance of all Architectural and Engineering Design Services, as stipulated in these Terms of Reference, for the PROJECT. Prospective bidders shall attach each individual's resume and PRC license of the (professional) staff with signature.

Design personnel may also be utilized for the construction phase provided that the same meet the minimum number of years of experience in the construction of similar projects.

For Construction Personnel

The key professionals and the respective qualifications of the CONSTRUCTION PERSONNEL shall be as follows:

Project Manager

The Project Manager shall be a licensed architect or engineer with at least ten (10) years relevant experience on similar and comparable projects in different locations. The Project Manager should have a proven record or managerial capability through the directing/managing of major civil engineering works, including projects of a similar magnitude.

Project Architect/Engineer

The Project Architect/Engineer shall be a licensed architect or engineer with at least five (5) years' experience in similar and comparable projects and shall preferably be knowledgeable in the application of rapid construction technologies.

Materials Engineer (M.E. I)

The Materials Engineer must be duly accredited with the DPWH and with at least five (5) years' experience in similar and comparable projects and shall preferably be knowledgeable in the application of rapid construction technologies.

Electrical Engineer

The Electrical Engineer must be duly-licensed with at least five (5) years' experience in similar and comparable projects in the installation of lighting, power distribution, communication systems (specifically structured and local area network cabling, PABX), building management systems.

Electronics and Communication Engineer

The Electronics and Communication Engineer must be duly-licensed with at least five (5) years' experience in similar and comparable projects in the installation of communications systems, fire detection and alarm system and preferably knowledgeable in the application of building automation and surveillance systems.

Mechanical Engineer

The Mechanical Engineer must be duly-licensed with at least five (5) years' experience in similar and comparable projects in the installation of HVAC and fire protection

Sanitary Engineer

The Sanitary Engineer must be duly-licensed with at least five (5) years' experience in similar and comparable projects in the installation of building water supply and distribution, plumbing.

Foreman

The Foreman must have at least ten (10) years' experience in similar and comparable projects and shall preferably be knowledgeable in the application of rapid construction technologies.

Safety officer

The Safety Officer must be an accredited safety practitioner by the Department of Labor and Employment (DOLE) and must have undergone the prescribed forty (40) hour Construction Safety and Health Training (COSH) and must have at least five (5) years' experience.

12.1(h)(iii)

The minimum major equipment requirements are the following:

Equipment	Quantity	Purpose
Earthmoving Equipment		
Bulldozer (D6/D7 class)	2	Clearing, grubbing, rough grading
Excavator (0.8 – 1.5 m ³ bucket)	2	Excavation for foundations, trenches, and septic tanks
Backhoe Loader	2	Light excavation, trenching, and loading
Wheel Loader	2	Loading, stockpiling, site clean-up
Motor Grader	1	Road grading, levelling of site roads
Dump Trucks (10-15 cu.m)	3	Hauling soil, aggregates, debris
Compaction Equipment		
Vibratory Road Roller	2	Compacting soil, base, and sub-base layers
Plate Compactor	2	Small area compaction (footpaths, sidewalks)
Concrete and Structural Works		
Transit Mixer (6 cu.m)	2	Concrete delivery on site
Concrete Pump	1	High-rise/long distance concrete placement

	Concrete Vibrator	2	Compaction of concrete for structural integrity
	Batching Plant (if on-site)	1	On-site concrete production (optional but ideal for large-scale works)
	Concrete Pouring Bucket (1.5 cu.m)		
	Submersible Dewatering Pump (2 HP single phase 220V)		
Lifting and Handling Equipment			
	Mobile Crane (25–50 tons)	1	Lifting of rebar, formwork, roof trusses
	Forklift	1	Handling construction materials inside compound
	Tower Crane (if multi-story)	1	Optional if structures are multi-level with tight working space
Roadworks and Utility Equipment			
	Asphalt Paver	1	Internal road paving
	Water Truck	1	Dust control, compaction support
	Concrete Cutter	2	Cutting pavement or slabs for utilities
	Trenching Machine	1	Efficient trenching for electrical, water, and sewer lines
Additional Temporary Support Equipment			
	<ul style="list-style-type: none"> ○ Generator Set – for uninterrupted power during construction ○ Welding Machines – for fabrication on site ○ Scaffolding Sets – for wall and ceiling works ○ Surveying Equipment – Total station, GPS, Theodolite ○ Site Office Containers & Storage 		
<p>Note: Any specified types and/or additional heavy equipment needed to the site development will be determined by the winning bidder.</p>			

12.4	The ABC is Three Hundred Million Pesos Only (₱300,000,000.00) . Any bid with a financial component exceeding this amount shall not be accepted.
14.1	The bid prices shall be quoted in Philippine Peso.
14.3	Not applicable
15.1	Bids will be valid for One Hundred Twenty (120) Calendar Days from bid opening.
16.1	The Bid Security shall be in the form of a Bid Securing Declaration or any of the following: <ol style="list-style-type: none"> 1. The amount of not less than ₱6,000,000.00 if bid security is in manager's check. 2. The amount of not less than ₱15,000,000.00 if Surety Bond.
16.2	The Bid Security shall be valid until 05 September 2026 .
16.3	Substitution of the bid security form is allowed. Bid Securing Declaration and the following forms may be used: <i>[choose at least two (2)]</i> <ol style="list-style-type: none"> a) Cash or Cashier's or Manager's Check issued by a Bank. b) Bank draft/guarantee or irrevocable Letter of Credit issued by a Bank: Provided, however, that it shall be confirmed or authenticated by a local Bank, if issued by a foreign bank. c) Surety bond callable upon demand issued by a surety or insurance company duly certified by the Insurance Commission as authorized to issue such security."
19	The address for submission of bids is BAC Conference Room, National Headquarters, NBP Reservation, Poblacion, Muntinlupa City . The deadline for submission of bids is on 05 May 2026 (0959H) .
21.5	<i>Insert value engineering clause if required, otherwise state "No further instructions."</i>
22.1	The date and time of bid opening is 05 May 2026 (1000H) . The place of bid opening is BAC Conference Room, National Headquarters, NBP Reservation, Poblacion, Muntinlupa City .
22.2(b)	For MEARB as award criterion, the date and time of bid opening of the financial proposals is on 19 May 2026 (1000H) .
25.3 (b)(i)	The quality component shall be assessed on the basis of criteria with corresponding numerical weights, which may include qualitative, environmental, or social aspects linked to the subject matter of the contract. These may include any or a combination of the following:

	<p>WEIGHTED TECHNICAL SCORE (WTS) EVALUATION CHECKLIST WITH POINTING SYSTEM</p> <p>(RA 12009 IRR – MEARB)</p> <table border="1"> <thead> <tr> <th>Description</th> <th>Points</th> </tr> </thead> <tbody> <tr> <td>1. QUALITY AND TECHNICAL MERIT</td> <td>20%</td> </tr> <tr> <td>2. AESTHETIC AND FUNCTIONAL DESIGN</td> <td>15%</td> </tr> <tr> <td>3. APPROACH AND METHODOLOGY</td> <td>15%</td> </tr> <tr> <td>4. ACCESSIBILITY</td> <td>5%</td> </tr> <tr> <td>5. TOOLS, EQUIPMENT, AND TECHNOLOGY</td> <td>5%</td> </tr> <tr> <td>6. SOCIAL, ENVIRONMENTAL, ECONOMIC, AND INNOVATIVE CHARACTERISTICS</td> <td>10%</td> </tr> <tr> <td>7. ORGANIZATION, QUALIFICATION, AND EXPERIENCE OF ASSIGNED PERSONNEL</td> <td>15%</td> </tr> <tr> <td>8. ONGOING CONTRACTS AND WORK COMMITMENTS</td> <td>5%</td> </tr> <tr> <td>9. AFTER-SALES SERVICE / TECHNICAL ASSISTANCE</td> <td>5%</td> </tr> <tr> <td>10. DELIVERY CONDITIONS (PERIOD AND PROCESS)</td> <td>2.5%</td> </tr> <tr> <td>11. DISPOSAL MEASURES</td> <td>2.5%</td> </tr> <tr> <td style="text-align: right;">TOTAL:</td> <td>100%</td> </tr> </tbody> </table>	Description	Points	1. QUALITY AND TECHNICAL MERIT	20%	2. AESTHETIC AND FUNCTIONAL DESIGN	15%	3. APPROACH AND METHODOLOGY	15%	4. ACCESSIBILITY	5%	5. TOOLS, EQUIPMENT, AND TECHNOLOGY	5%	6. SOCIAL, ENVIRONMENTAL, ECONOMIC, AND INNOVATIVE CHARACTERISTICS	10%	7. ORGANIZATION, QUALIFICATION, AND EXPERIENCE OF ASSIGNED PERSONNEL	15%	8. ONGOING CONTRACTS AND WORK COMMITMENTS	5%	9. AFTER-SALES SERVICE / TECHNICAL ASSISTANCE	5%	10. DELIVERY CONDITIONS (PERIOD AND PROCESS)	2.5%	11. DISPOSAL MEASURES	2.5%	TOTAL:	100%
Description	Points																										
1. QUALITY AND TECHNICAL MERIT	20%																										
2. AESTHETIC AND FUNCTIONAL DESIGN	15%																										
3. APPROACH AND METHODOLOGY	15%																										
4. ACCESSIBILITY	5%																										
5. TOOLS, EQUIPMENT, AND TECHNOLOGY	5%																										
6. SOCIAL, ENVIRONMENTAL, ECONOMIC, AND INNOVATIVE CHARACTERISTICS	10%																										
7. ORGANIZATION, QUALIFICATION, AND EXPERIENCE OF ASSIGNED PERSONNEL	15%																										
8. ONGOING CONTRACTS AND WORK COMMITMENTS	5%																										
9. AFTER-SALES SERVICE / TECHNICAL ASSISTANCE	5%																										
10. DELIVERY CONDITIONS (PERIOD AND PROCESS)	2.5%																										
11. DISPOSAL MEASURES	2.5%																										
TOTAL:	100%																										
25.3 (b)(iii)	<i>[indicate the weights given to the price and quality proposals, including the sustainability of materials or structures with green specifications]</i>																										
25.3(b)	70% Quality Proposal 30% Price Proposal																										
25.3 (c)(i)	<i>“Not applicable”</i>																										
25.5 (a)	<p>All infrastructure projects are packaged in lots listed below. Bidders shall have the option of submitting a proposal on any or all lots and evaluation and contract award will be undertaken on a per lot basis. Lots shall not be divided further into sub-lots for the purpose of bidding, evaluation, and contract award.</p> <p>In all cases, the NFCC computation, if applicable, must be sufficient for all the lots or contracts to be awarded to the Bidder.</p>																										
25.5 (b)	Bid correction shall be allowed.																										

25.6	No further instructions.
26.1	<p>Within a non-extendible period of five (5) calendar days from receipt by the Bidder of the notice from the BAC that it submitted the Most Economic Advantageous Bid (MEAB), the Bidder shall submit its;</p> <ol style="list-style-type: none"> 1. Latest income and business tax returns filed for the preceding quarter which should not be earlier than two (2) quarters from the date of submission and receipt of bid. 2. Valid and Current Registration Certificate (SEC Certificate of Registration for Corporation or DTI Certificate of Registration for Sole Proprietorship or CDA Certificate of Registration for Cooperative) 3. Valid and Current Mayor's or Business Permit 4. Valid and Current Tax Clearance 5. Audited Financial Statement <p>Three (3) sets photocopy of Technical and Financial Envelope duly marked as "Copy No.1", "Copy No.2" and "Copy No.3"</p>
29.3(f)	<p><i>List additional contract documents relevant to the Project that may be required by existing laws and/or the Procuring Entity, such as construction schedule and S-curve, manpower schedule, construction methods, equipment utilization schedule, construction safety and health program approved by the DOLE, and Program Evaluation and Review Technique (PERT), Critical Path Method (CPM) or other acceptable tools of project scheduling.</i></p>
30.2	"Not applicable"
30.3	<p>The Performance Security shall be in the form: <i>[choose one from any of the following:]</i></p> <ol style="list-style-type: none"> 1) The amount of not less than _____ <i>[Insert 10% of the contract price]</i>, if performance security is in cash. 2) The amount of not less than _____ <i>[Insert 10% of the contract price]</i>, if performance security is in cashier's check. 3) The amount of not less than _____ <i>[Insert 10% of the contract price]</i>, if performance security is in manager's check. 4) The amount of not less than _____ <i>[Insert 10% of the contract price]</i> if performance security is in bank draft. 5) The amount of not less than _____ <i>[Insert 10% of the contract price]</i> if performance security is in guarantee. 6) The amount of not less than _____ <i>[insert 10% of the contract price]</i> if performance security is irrevocable LoC. Or 7) The amount of not less than _____ <i>[insert 30% of the contract price]</i> if performance security is Surety Bond.

Section IV. General Conditions of Contract

1) General Terms

In this Contract, the following terms shall be interpreted as indicated:

- 1.1 The **Intended Completion Date** refers to the date specified in the **SCC** when the Contractor is expected to have completed the Works. The intended Completion Date may be revised only by the Procuring Entity by issuing an extension of time or an acceleration order.
- 1.2 The **Procuring Entity** is the party who employs the Contractor to carry out the Works stated in the **SCC**.
- 1.3 The **Site** is the place provided by the Procuring Entity where the Works shall be executed and any other place or places which may be designated in the **SCC**, or notified to the Contractor by the Procuring Entity as forming part of the Site.
- 1.4 The **Start Date**, as specified in the **SCC**, is the date when the Contractor is obliged to commence execution of the Works. It does not necessarily coincide with any of the Site Possession Dates.
- 1.5 **Work(s)** refer to the Permanent Works and Temporary Works to be executed by the Contractor in accordance with this Contract, including (i) the furnishing of all labor, materials, equipment and others incidental, necessary or convenient to the complete execution of the Works; (ii) the passing of any tests before acceptance by the Procuring Entity; (iii) and the carrying out of all duties and obligations of the Contractor imposed by this Contract as described in the **SCC**. In line with this, Temporary Works are works designed, constructed, and installed by the Contractor that are needed for construction or installation of the Permanent Works, which are subsequently removed.

2) Interpretation

- 2.1 In interpreting the Conditions of Contract, singular also means plural, male also means female or neuter, and the other way around. Headings have no significance. Words have their normal meaning under the language of this Contract unless specifically defined. The Procuring Entity will provide instructions clarifying queries about the Conditions of Contract.
- 2.2 If sectional completion is specified in the **SCC**, references in the Conditions of Contract to the Works, the Completion Date, and the Intended Completion Date apply to any Section of the Works (other than references to the Completion Date and Intended Completion Date for the whole of the Works).
- 2.3 The documents forming this Contract shall be interpreted in the following order of priority:
 - a) Contract Agreement;
 - b) Bid Data Sheet;
 - c) Instructions to Bidders;

- d) Addenda to the Bidding Documents;
- e) Special Conditions of Contract;
- f) General Conditions of Contract;
- g) Specifications;
- h) Bill of Quantities; and
- i) Drawings.

3) **Governing Language and Law**

- 3.1 This Contract shall be interpreted in accordance with the laws of the Republic of the Philippines.
- 3.2 This Contract has been executed in the English language, which shall be the binding and controlling language for all matters relating to the meaning or interpretation of this Contract. All correspondence and other documents pertaining to this Contract which are exchanged by the parties shall be written in English.

4) **Communications**

Communications between parties that are referred to in the Conditions shall be effective only if made in writing. A notice shall be effective only when it is received by the concerned party.

5) **Possession of Site**

- 5.1 On the date specified in the **SCC**, the Procuring Entity shall grant the Contractor possession of so much of the Site as may be required to enable it to proceed with the execution of the Works. If the Contractor suffers delay or incurs cost from failure on the part of the Procuring Entity to give possession in accordance with the terms of this clause, the Procuring Entity shall give the Contractor a Contract Time Extension and certify such sum as fair to cover the cost incurred, which sum shall be paid by Procuring Entity.
- 5.2 If possession of a portion is not given by the date stated in the **SCC** Clause 1.3, the Procuring Entity will be deemed to have delayed the start of the relevant activities. The resulting adjustments in contract time to address such delay shall be in accordance with **GCC** Clause 44.
- 5.3 The Contractor shall bear all costs and charges for special or temporary right-of-way required by it in connection with access to the Site. The Contractor shall also provide at its own cost any additional facilities outside the Site required by it for purposes of the Works.
- 5.4 The Contractor shall allow the Procuring Entity and any person authorized by the Procuring Entity access to the Site and to any place where work in connection with this Contract is being carried out or is intended to be carried out.

6) The Contractor's Obligations

- 6.1 The Contractor shall carry out the Works properly and in accordance with this Contract. The Contractor shall provide all supervision, labor, Materials, Plant and Contractor's Equipment, which may be required. All Materials and Plant on Site shall be deemed to be the property of the Procuring Entity.
- 6.2 The Contractor shall commence execution of the Works on the Start Date and shall carry out the Works in accordance with the Program of Work submitted by the Contractor, as updated with the approval of the Procuring Entity, and complete them by the Intended Completion Date.
- 6.3 The Contractor shall be responsible for the safety of all activities on the Site.
- 6.4 The Contractor shall carry out all instructions of the Procuring Entity that comply with the applicable laws where the Site is located.
- 6.5 The Contractor shall employ the key personnel named in the Schedule of Key Personnel, as referred to in the **SCC**, to carry out the supervision of the Works. The Procuring Entity will approve any proposed replacement of key personnel only if their relevant qualifications and abilities are equal to or better than those of the personnel listed in the Schedule.
- 6.6 If the Procuring Entity asks the Contractor to remove a member of the Contractor's staff or work force, for justifiable cause, the Contractor shall ensure that the person leaves the Site within seven (7) days and has no further connection with the Work in this Contract.
- 6.7 During Contract implementation, the Contractor and its subcontractors shall abide at all times by all labor laws, including child labor related enactments, and other relevant rules.
- 6.8 The Contractor shall submit to the Procuring Entity for consent the name and particulars of the person authorized to receive instructions on behalf of the Contractor.
- 6.9 The Contractor shall cooperate and share the Site with other contractors, public authorities, utilities, and the Procuring Entity between the dates given in the schedule of other contractors particularly when they shall require access to the Site. The Contractor shall also provide facilities and services for them during this period. The Procuring Entity may modify the schedule of other contractors, and shall notify the Contractor of any such modification thereto.
- 6.10 Should anything of historical or other interest or of significant value be unexpectedly discovered on the Site, it shall be the property of the Procuring Entity. The Contractor shall notify the Procuring Entity of such discoveries and carry out the Procuring Entity's instructions in dealing with them.

7) Subcontracting

- 7.1 Unless otherwise indicated in the **SCC**, the Contractor shall not subcontract portions of the Works beyond the percentage specified in **BDS** Clause 8.1. If subcontracting is allowed, the arrangement, including the timing for submission of the subcontractor's eligibility documents, shall be disclosed.

7.2 For subcontracting arrangements, the following rules shall apply for both locally-funded projects and to projects financed through Official Development Assistance, except those covered by treaty, or international, or executive agreements:

- a) The subcontracted portion of the contract shall be subject to the approval of the HoPE and the following conditions:
 - i) The subcontracted portion shall not exceed fifty percent (50%), or a different percentage on a per project basis as approved by the GPPB. The threshold percentages fixed herein shall be subject to the periodic review and adjustments as may be deemed appropriate by the GPPB; and
 - ii) The subcontracted portion shall be limited to components that are not deemed "significant or material" to the project as determined by the Procuring Entity.
- b) Subcontracting arrangement, if allowed, including the time of submission of the eligibility documents of the subcontractor, shall be disclosed in the Bidding Documents;
- c) Subcontractors must meet the eligibility criteria and shall submit the same eligibility documents as the general contractor.

Failure of a subcontractor to meet the eligibility criteria does not affect the eligibility of the general contractor for the procurement project. In such case, the portion intended to be subcontracted to the ineligible subcontractor shall be assumed by the general contractor;

- d) The general contractor shall remain liable for the subcontractor's actions, defaults, delays, and negligence;
- e) The general contractor and the subcontractor are obliged to comply with the provisions of the contract and shall share liability, jointly and severally, in cases of violation of safety standards or other labor standards insofar as the subcontracted portion is concerned; and
- f) For purposes of post-qualification in accordance with its objective and process under the IRR, the value of the entire completed and accepted Project, including the subcontracted portion, shall be credited as experience of the general contractor. In the case of the subcontractor, the following rules shall apply:
 - i) The subcontractor shall get credit for one hundred percent (100%) of the value of the subcontracted portion of the project performed;
 - ii) Subcontractors shall be eligible to concessional windows of GFIs that treat receivables from the government as loan security; the receivables of subcontractors due from their general contractor shall similarly be accepted as loan security by GFIs; and

- iii) Contract performance monitoring, such as the use of CPES, among others, shall also be mandatorily applied to the work experience of the subcontractors.

8) Advance Payment

- 8.1 The Procuring Entity shall make an advance payment on the Contract Price to the Contractor in an amount not exceeding fifteen percent (15%) of the total contract price to be made in lump sum or, at the most, two installments according to a schedule specified in the **SCC**.
- 8.2 The advance payment shall be made only upon:
 - i) Written request of the contractor which shall form part of the contract document; and
 - ii) Submission of an irrevocable standby Letter of Credit of equivalent value from a bank as confirmed by the Procuring Entity; a bank guarantee; or a surety bond callable upon demand issued by a duly licensed surety or insurance company, at the option of the Procuring Entity.
- 8.3 The advance payment shall be recovered from the Contractor through deductions in amounts equivalent to the percentage of the total contract price that corresponds to the value of the advance payment granted.
- 8.4 Once a month, Contractors may submit documents, such as Monthly Certificates,⁶ to show the progress or partial completion of a project. The Contractor may reduce its standby letter of credit or guarantee instrument by the amounts refunded by the Monthly Certificates, or any equivalent document subject to auditing and accounting rules, in the advance payment.

9) Progress Payments

- 9.1 Once a month, the Contractor may submit a statement of work accomplished (SWA) or progress billing and corresponding request for progress payment for work accomplished. The SWA should show the amounts which the Contractor considers itself to be entitled to up to the end of the month, to cover (i) the cumulative value of the Works it executed to date, based on the items in the Bill of Quantities, and (ii) adjustments made for approved Variation Orders executed. Alternatively, the Procuring Entity may require in the Bidding Documents that the SWA or progress billing and the corresponding request for progress payment may only be submitted upon actual completion of the Infrastructure Project or a specific portion, segment, milestone or phase thereof.

The Procuring Entity or Project Engineer shall check the Contractor's SWA and certify the amount to be paid to the Contractor as progress payment. Materials and equipment delivered onsite but not yet incorporated in the Works shall not be included for payment, except as otherwise stipulated in the **SCC**.

⁶ Commission on Audit (COA) Circular 2012-001.

- 9.2 The Procuring Entity shall deduct the following from the certified gross amounts to be paid to the Contractor as progress payment:
- a) Cumulative value of the work previously certified and paid for.
 - b) Portion of the advance payment to be recouped.
 - c) Retention money in accordance with the conditions of the contract.
 - d) Amount to cover third-party liabilities.
 - e) Amount to cover uncorrected discovered defects in the Works.
- 9.3 Payments shall be adjusted by deducting therefrom the amounts for advance payments and retention. The Procuring Entity shall pay the Contractor the amounts certified by the Procuring Entity within twenty-eight (28) days from the date each certificate was issued. No payment of interest for delayed payments and adjustments shall be made by the Procuring Entity.
- 9.4 The first progress payment may be paid by the Procuring Entity to the Contractor, as indicated in the **SCC**; Provided, That at least a percentage of the Works has been accomplished as certified by the Procuring Entity and as indicated in the **SCC**.
- 9.5 Items of the Works for which a price of "0" (zero) has been entered will not be paid for by the Procuring Entity and shall be deemed covered by other rates and prices in the Contract.

10) Payment Documents

- 10.1 Subject to existing accounting and auditing rules and regulations,⁷ the Contractor shall submit to the Procuring Entity monthly statements of the estimated value of the work executed less the cumulative amount certified previously.
- 10.2 The Procuring Entity shall check the Contractor's monthly statement and certify the amount to be paid to the Contractor.
- 10.3 The value of Work executed shall:
- a) be determined by the Procuring Entity;
 - b) comprise the value of the quantities of the items in the Bill of Quantities completed; and
 - c) include the valuations of approved variations.
- 10.4 The Procuring Entity may exclude any item certified in a previous certificate or reduce the proportion of any item previously certified in any certificate in the light of later information.

⁷ COA Circular No. 2012-001.

11) Retention

11.1 The Procuring Entity shall retain from each payment due to the Contractor an amount equal to a percentage thereof using the rate as specified in GCC Clause 11.2. The said amount will serve to guarantee indemnity for uncorrected discovered defects and third-party liabilities arising from this Contract. This retention money shall be utilized if the contractor fails to repair the discovered defects. Should the retention money be insufficient, the PE may forfeit the performance security, which may ultimately lead to the termination of the contract.⁸

11.2 Progress payments are subject to retention of ten percent (10%) referred to as the retention money. Such retention shall be based on the total amount due to the Contractor prior to any deduction and shall be retained from every progress payment until fifty percent (50%) of the value of the Works, as determined by the Procuring Entity, are completed.

If, after fifty percent (50%) completion, the work is satisfactorily done and on schedule, no additional retention shall be made; otherwise, the ten percent (10%) retention shall be imposed, which may be decreased to 5 percent (5%) by the Procuring Entity based on justifiable causes.⁹

11.3 The total retention money shall be due for release upon final acceptance of the Works. The Contractor may, however, request the substitution of the retention money for each progress billing with irrevocable standby Letters of Credit from a bank, bank guarantees or surety bonds callable on demand, of amounts equivalent to the retention money substituted for and acceptable to Government; Provided, That the project is on schedule and is satisfactorily undertaken. Otherwise, the ten (10%) percent retention shall be made. Said irrevocable standby letters of credit, bank guarantees and/or surety bonds, to be posted in favor of the Government shall be valid for a duration to be determined by the concerned implementing office/agency or Procuring Entity and will answer for the purpose for which the ten (10%) percent retention is intended, *i.e.*, to cover uncorrected discovered defects and third party liabilities.

11.4 On completion of the whole Works, the Contractor may substitute retention money with an “on demand” Bank guarantee in a form acceptable to the Procuring Entity.

12) Performance Security

12.1 Within ten (10) calendar days from receipt of the Notice of Award from the Procuring Entity, but in no case later than the signing of the contract by both parties, the winning Contractor shall furnish the performance security in any of the forms prescribed in **ITB** Clause 30 in relation to **BDS** Clause 30.2 and 30.3.

⁸ Supreme Court rulings (e.g. New Bian Yek Commercial, Inc. vs. Office of the Ombudsman, et. al., GR No. 169338[2009], and Tondo Medical Center vs. Rante, G.R. No. 230645 [2019] have affirmed this purpose, stating that retention money is a form of security to ensure the satisfactory completion of works and to cover any defects or third-party claims that may arise after project completion.

⁹ Section 71.2.8 of the IRR.

- 12.2 The performance security posted in favor of the Procuring Entity shall be forfeited in the event it is established that the Contractor is in default in any of its obligations under the contract.
- 12.3 The performance security shall remain valid until issuance by the Procuring Entity of the Certificate of Final Acceptance. In case the performance security issued is valid for a specific period shorter than the term of the contract, including the defects liability period, the same shall be renewed or extended as often as necessary and immediately submitted to the Procuring Entity. In case of approved contract time extensions, the Contractor shall cause the extension of the validity of the performance security to cover the said extensions.
- 12.4 The performance security may be released by the Procuring Entity after the issuance of the Certificate of Final Acceptance; Provided, That the Procuring Entity has no claims filed against the performance security.
- 12.5 The Contractor shall post an additional performance security following the amount and form specified in **ITB Clause 30** to cover any cumulative increase of more than ten percent (10%) over the original value of the contract as a result of change orders, extra work orders and supplemental agreements, as the case may be.
- 12.6 In case of a reduction in the contract value or for partially completed Works under the contract which are usable and accepted by the Procuring Entity the use of which, in the judgment of the implementing agency or the Procuring Entity, will not affect the structural integrity of the entire project, the Procuring Entity shall allow a proportional reduction in the original performance security, provided that any such reduction is more than ten percent (10%) and that the aggregate of such reductions is not more than fifty percent (50%) of the original performance security.
- 12.7 Unless otherwise indicated in the **SCC**, the Contractor, by entering into the Contract with the Procuring Entity, acknowledges the right of the Procuring Entity to institute action pursuant to Act No. 3688¹⁰ against any subcontractor be they an individual, firm, partnership, corporation, or association supplying the Contractor with labor, materials and/or equipment for the performance of this Contract.

13) Detailed Engineering and Site Investigation Reports

- 13.1 The Contractor, in preparing the Bid, shall rely on all Site Investigation Reports referred to in the **SCC**, supplemented by any information obtained by the Contractor.
- 13.2 Detailed engineering shall proceed only on the basis of the feasibility or preliminary engineering study made which establishes the technical viability of the project and conformance to land use and zoning guidelines prescribed by existing laws. The findings contained in the feasibility study, if undertaken for the project, shall be examined. If, in the course of this exercise, it is found that amendments would be desirable in the design standards of principal features, as proposed, specific recommendations for such changes shall be supported

¹⁰ Also known as "An Act for the Protection of Persons Furnishing Material and Labor for the Construction Of Public Works".

by detailed justifications, including their effects on the cost, and the economic justifications, if necessary.

13.3 A schedule of detailed engineering activities shall include the following:

- a) Survey;
- b) Site Investigation;
- c) Soils and Foundation Investigation;
- d) Construction Materials Investigation;
- e) Preparation of Design Plans;
- f) Preparation of Technical Specifications;
- g) Preparation of Quantity and Cost Estimates;
- h) Preparation of Scope of Work;
- i) Preparation of Proposed Construction Schedule (and estimated Cash Flow for projects with Schedule over six (6) months);
- j) Preparation of Site or Right-of-Way Plans including Schedule of Acquisition;
- k) Preparation of Utility Relocation Plan;
- l) Preparation and Submission of Design Report;
- m) Environmental Impact Statement for critical project, as defined by the Department of Environment and Natural Resources;
- n) Preparation of minimum requirements for a Construction Safety and Health Program for the project being considered;
- o) Value Engineering Studies; and
- p) Preparation of report on asset climate hazards, risk assessment, disaster response strategies, and readiness planning.

13.4 Work under detailed architectural and engineering design shall include, among others, the items stated in Section 8.3 of the IRR.

14) Licenses and Permits

The Procuring Entity may, if requested by the Contractor, assist him in applying for permits, licenses or approvals, which are required for the Works.

15) Contractor's Risk and Warranty Security

15.1 From the time project construction commenced up to final acceptance, the Contractor shall assume full responsibility for any damage or destruction of the works, except those occasioned by force majeure; and the safety, protection, security, and convenience of its personnel, third parties, and the public at large,

as well as the works, equipment, installation and the like to be affected by its construction work.

- 15.2 The defects liability period for infrastructure projects shall be one (1) year from project completion up to final acceptance by the Procuring Entity. During this period, the Contractor shall undertake the repair works, at its own expense, of any damage to the Works on account of the use of materials of inferior quality, defects in the construction, or due to any violation of the terms of the contract, within ninety (90) calendar days from the time the HoPE has issued an order to undertake repair. In case of failure or refusal to comply with this mandate, the Procuring Entity shall undertake such repair works and shall be entitled to full reimbursement of expenses incurred therein upon demand.
- 15.3 The defects liability period shall be covered by the performance security of the Contractor required in Section 68 of the IRR, which shall guarantee that the Contractor performs its responsibilities stated in **GCC** Clause 15.1 Unless otherwise indicated in the **SCC**, in case the Contractor fails to comply with the preceding paragraph, the Procuring Entity shall forfeit its performance security, subject its properties to attachment or garnishment proceedings, and may impose the appropriate penalty under Sections 99, 100, and 101 of the IRR. All payables of the GoP in its favor shall be offset to recover the costs.
- 15.4 The following persons shall be held responsible for “Structural Defects,” i.e., major faults or flaws or deficiencies in one or more key structural elements of the project which may lead to structural failure of the completed elements or structure, or “Structural Failures,” i.e., where one or more key structural elements in an infrastructure facility fails or collapses, thereby rendering the facility or part thereof incapable of withstanding the design loads, and/or endangering the safety of the users or the general public:
 - a) Contractor – Where Structural Defects or Failures arise due to faults attributable to improper construction, use of inferior quality/substandard materials, and any violation of the contract plans and specifications, the Contractor shall be held liable;
 - b) Consultants – Where Structural Defects or Failures arise due to faulty and/or inadequate design and specifications as well as construction supervision, then the consultant who prepared the design or undertook construction supervision for the project shall be held liable;
 - c) Procuring Entity’s Representatives or Project Manager or Construction Managers and Supervisors – The project owner’s representative, project manager, construction manager, and supervisor shall be held liable in cases where the Structural Defects or Failures are due to their willful intervention in altering the designs and other specifications; negligence or omission in not approving or acting on proposed changes to noted defects or deficiencies in the design and/or specifications and the use of substandard construction materials in the project;
 - d) Third Parties - Third Parties shall be held liable in cases where Structural Defects or Failures are caused by work undertaken by them such as leaking pipes, diggings or excavations, underground cables and electrical wires, underground tunnel, mining shaft and the like, in which case the applicable warranty to such structure should be levied to third parties for their construction or restoration works; and

- e) Users - In cases where Structural Defects or Failures are due to abuse or misuse by the End-User or Implementing Unit of the constructed facility and/or non-compliance by a user with the technical design limits and/or intended purpose of the same, then the user concerned shall be held liable.

15.5 The warranty against Structural Defects or Failures, except those occasioned by force majeure, shall cover the period specified in the **SCC** reckoned from the date of issuance of the Certificate of Final Acceptance by the Procuring Entity. On the other hand, such warranty shall likewise be applied against non-structural defects for instances that pertain to faults or deficiencies in non-load bearing components or finishes of the Project, such as minor cracks, leaks, or defects in workmanship or materials, which do not affect the stability or safety of the structure but may impact its appearance, functionality, or usability.

15.6 To guarantee that the Contractor shall perform its responsibilities, it shall be required to post a warranty security, which shall be stated in Philippine Peso, in the form chosen by the Procuring Entity in accordance with the following schedule:

Form of Warranty	Amount of Warranty Security Not less than the Percentage (%) of Total Contract Price
(a) Cash or letter of credit issued by bank; Provided, however, that the letter of credit shall be confirmed or authenticated by a local bank, if issued by a foreign bank. For biddings conducted by LGUs, the Letter of Credit may be issued by other banks certified by the BSP as authorized to issue such financial instrument.	Five Percent (5%)
(b) Bank guarantee confirmed by bank. For biddings conducted by LGUs, the bank draft/guarantee may be issued by other banks certified by the BSP as authorized to issue such financial instrument.	Ten Percent (10%)
(c) Surety bond callable upon demand issued by GSIS or any surety or insurance company duly certified by the Insurance Commission	Thirty Percent (30%)

15.7 The warranty security shall be stated in Philippine Peso and shall remain effective within one (1) year from the date of issuance of the Certificate of Final Acceptance by the Procuring Entity, and returned only after the lapse of the said one (1) year period. This one (1) year period shall cover both structural and non-structural defects or failures; Provided, that in cases of structural defects or failures, warranties beyond the one (1) year period shall be subject to applicable laws, rules, and regulations such as the New Civil Code of the Philippines.

- 15.8 In case of structural/non-structural defects or failure occurring during the applicable warranty period provided in **GCC** Clause 15.5, the Procuring Entity shall undertake the necessary restoration or reconstruction works and shall be entitled to full reimbursement by the parties found to be liable for expenses incurred therein upon demand, without prejudice to the imposition of administrative sanctions as prescribed by RA No. 12009 and without prejudice to the imposition of civil and criminal sanctions as provided under applicable laws against the responsible persons as well as the forfeiture of the warranty security posted in favor of the Procuring Entity.

16) Procuring Entity's Risk

- 16.1 From the Start Date until the Certificate of Final Acceptance has been issued, the following are risks of the Procuring Entity:
- a) The risk of personal injury, death, or loss of or damage to property (excluding the Works, Plant, Materials, and Equipment), which are due to:
 - i) any type of use or occupation of the Site authorized by the Procuring Entity after the official acceptance of the Works; or
 - ii) negligence, breach of statutory duty, or interference with any legal right by the Procuring Entity or by any person employed or contracted by it, except the Contractor.
 - b) The risk of damage to the Works, Plant, Materials, and Equipment to the extent that it is due to a fault of the Procuring Entity or in the Procuring Entity's design, or due to war or radioactive contamination directly affecting the country where the Works are to be executed.

17) Insurance

- 17.1 The Contractor shall, under its name and at its own expense, obtain and maintain, for the duration of this Contract, the following insurance coverage:
- a) Contractor's All Risk Insurance, with an exception for Simple Infrastructure Projects, as applicable;
 - b) Transportation to the project Site of Equipment, Machinery, and Supplies owned by the Contractor;
 - c) Personal injury or death of Contractor's employees; and
 - d) Comprehensive insurance for third party liability to Contractor's direct or indirect act or omission causing damage to third persons.
- 17.2 The Contractor shall provide evidence to the Procuring Entity that the insurances required under this Contract have been effected and shall, within a reasonable time, provide copies of the insurance policies to the Procuring Entity.
- 17.3 The Contractor shall notify the insurers of changes in the nature, extent, or program for the execution of the Works and ensure the adequacy of the insurances at all times in accordance with the terms of this Contract and shall

produce to the Procuring Entity the insurance policies in force including the receipts for payment of the current premiums.

The above insurance policies shall be obtained from any reputable insurance company approved by the Procuring Entity.

- 17.4 If the Contractor fails to obtain and keep in force the insurances referred to herein or any other insurance required to be obtained under the terms of this Contract, the Procuring Entity may obtain and keep in force any such insurances and pay such premiums as may be necessary for the purpose. From time to time, the Procuring Entity may deduct the amount it shall pay for said premiums including twenty-five percent (25%) therein from any monies due, or which may become due, to the Contractor, without prejudice to the Procuring Entity exercising its right to impose other sanctions against the Contractor pursuant to the provisions of this Contract.
- 17.5 In the event the Contractor fails to observe the above safeguards, the Procuring Entity may, at the Contractor's expense, take whatever measure is deemed necessary for its protection and that of the Contractor's personnel and third parties, and/or order the interruption of dangerous Works. In addition, the Procuring Entity may refuse to make the payments under **GCC** Clause 9 until the Contractor complies with this Clause.
- 17.6 The Contractor shall immediately replace the insurance policy obtained as required in this Contract, without need of the Procuring Entity's demand, with a new policy issued by a new insurance company acceptable to the Procuring Entity for any of the following grounds:
- a) The issuer of the insurance policy to be replaced has:
 - i) become bankrupt;
 - ii) been placed under receivership or under a management committee;
 - iii) been sued for suspension of payment;
 - iv) been suspended by the Insurance Commission and its license to engage in business or its authority to issue insurance policies has been cancelled; or
 - v) Where reasonable grounds exist that the insurer may not be able, fully and promptly, to fulfill its obligation under the insurance policy.

18) Liquidated Damages

- 18.1 When the Contractor fails to satisfactorily complete the Works under the contract within the specified contract duration, inclusive of duly granted time extensions, if any, the Contractor shall be liable for liquidated damages in an amount equal to at least one-tenth (1/10) of one percent (1%) of the cost of the unperformed portion of the Works for every day of delay.
- 18.2 In computing liquidated damages, the Procuring Entity shall determine the usability of the project. A project or a portion thereof may be deemed usable

when it starts to provide the desired benefits as certified by the End-User or Implementing Unit and approved by the HoPE.

- 18.3 To be entitled to liquidated damages, the Procuring Entity does not have to prove that it has incurred actual damages. Such amount shall be deducted from any money due, or which may become due the Contractor under the contract, collected from the retention money or other securities posted by the Contractor, or a combination thereof, whichever is convenient to the Procuring Entity.
- 18.4 In case the total sum of liquidated damages reaches ten percent (10%) of the total contract price, the Procuring Entity may rescind or terminate the contract, without prejudice to other courses of action and remedies available under the circumstances.
- 18.5 If the Intended Completion Date is extended after liquidated damages have been paid, the Procuring Entity shall correct any overpayment of liquidated damages by the Contractor by adjusting the next payment schedule.

19) Settlement of Disputes

- 19.1 Any dispute arising from the implementation of a contract covered by the Act and the IRR shall primarily be resolved and settled amicably by mutual consultation or agreement.
- 19.2 In case of failure to settle the dispute amicably, the parties may mutually agree in writing to resort to other modes of alternative dispute resolution (ADR) to promote efficiency in the procurement process. Accordingly, they are encouraged to select the most expeditious mode of ADR available.

If arbitration is chosen as the ADR method, this shall be incorporated as a provision in the contract and referred to the Arbitrator specified in the **SCC**.
- 19.3 If the dispute remains unresolved after exhausting the remedies provided above, it may be submitted to other forms of ADR, such as mediation, conciliation, early neutral evaluation, mini-trial, or any combination thereof, in accordance with RA No. 9285, otherwise known as the "Alternative Dispute Resolution Act of 2004". However, disputes that are within the competence or jurisdiction of the Construction Industry Arbitration Commission shall be referred to the same for resolution.¹¹

20) Liability of the Contractor

Subject to additional provisions, if any, set forth in the **SCC**, the Contractor's liability under this Contract shall be as provided by the laws of the Republic of the Philippines.

21) Termination for Breach of Contract

- 21.1 The Procuring Entity shall terminate the contract for breach thereof when any of the following conditions are present:

¹¹ Executive Order No. 1008 (Construction Industry Arbitration Law); and Construction Industry Arbitration Commission Revised Rules of Procedure.

- a) Due to the Contractor's fault and while the project is on-going, it has incurred negative slippage of fifteen percent (15%) or more in accordance with Presidential Decree No. 1870, s. 1983;
- b) Due to the Contractor's fault and after the contract time has expired, it has incurred a negative slippage of ten percent (10%) or more in the completion of the work;
- c) The Contractor abandons the contract works, plainly demonstrates an intention not to continue the performance of the Contractor's obligations under the contract, refuses or fails to comply with the Procuring Entity's instructions, or fails to proceed expeditiously and without delay despite a written notice by the Procuring Entity;
- d) When the Contractor, without reasonable excuse, fails to comply with the Notice of Rejection given by the Project Engineer that, after examination therein, the Infrastructure Project is found to be defective or otherwise not in accordance with the Contract, or a Project Engineer's instruction to conduct remedial work, within 30 days after receiving the said notice;
- e) The Contractor does not actually have on the project site the minimum essential equipment listed on the Bid necessary to prosecute the Works in accordance with the approved work plan and equipment deployment schedule as required for the project;
- f) The Contractor does not execute the Works in accordance with the contract or persistently or flagrantly neglects to carry out its obligations under the contract;
- g) The Contractor neglects or refuses to remove materials or to perform a new work that has been rejected as defective or unsuitable;
- h) The Contractor subcontracts any part of the contract works without approval by the Procuring Entity; or
- i) The Contractor becomes bankrupt or insolvent; goes into liquidation, administration, reorganization, winding-up, or dissolution; becomes subject to the appointment of a liquidator, receiver, administrator, manager, or trustee; enters into a composition or arrangement with the Contractor's creditors; or any act is done or any event occurs which is analogous to or has a similar effect to any of these acts or events under applicable laws.

21.2 All materials on the Site, Plant, Works, including Equipment paid under this Contract, including those identified by the Procuring Entity in the **SCC** pursuant to GCC Clause 9.1, shall be deemed to be the property of the Procuring Entity if this Contract is terminated because of the Contractor's breach.

22) Termination Due to Force Majeure

22.1 For purposes of this Contract the terms "*force majeure*" and "fortuitous event" may be used interchangeably. In this regard, a fortuitous event or *force majeure* shall be interpreted to mean an event which could not have been foreseen, or though foreseen, was inevitable. It shall not include ordinary

unfavorable weather conditions, and any other cause the effects of which could have been avoided with the exercise of reasonable diligence by the Contractor.

- 22.2 If this Contract is discontinued by an outbreak of war or by any other similar event entirely outside the control of either the Procuring Entity or the Contractor, the Procuring Entity shall certify that this Contract has been discontinued. The Contractor shall make the Site safe and stop work as quickly as possible after receiving the certificate and shall be paid for all Works carried out before receiving it and for any Work carried out afterwards to which a commitment was made by the Procuring Entity.
- 22.3 If the event continues for a period of eighty-four (84) days, either party may then give notice of termination, which shall take effect twenty-eight (28) days after the giving of the notice.
- 22.4 After termination, the Contractor shall be entitled to payment of the unpaid balance of the value of the Works executed and of the materials and Plant, in relation to GCC Clause 9.1 and 21.2, adjusted by the following:
- (a) any sum to which the Contractor is entitled under **GCC** Clause 30; and
 - (b) any sum to which the Procuring Entity is entitled.
- 22.5 The net balance due shall be paid or repaid within a reasonable time period from the time of the notice of termination.

23) Termination by Contractor

The Contractor may terminate this Contract with the Procuring Entity if the Works are completely stopped for a continuous period of at least sixty (60) calendar days through no fault of its own, due to any of the following reasons:

- a) Failure of the Procuring Entity to deliver, within a reasonable time, supplies, materials, right-of-way, or other items it is obligated to furnish under the terms of this Contract;
- b) Substantial failure of the Procuring Entity to perform its obligations under the contract, and such failure constitutes a material breach of the Procuring Entity's obligations under the contract;
- c) Prolonged suspension by the Procuring Entity, through no fault of the Contractor, which affects the substantial part of the Infrastructure Project; or
- d) The prosecution of the Work is disrupted by the adverse peace and order situation, as certified by the Armed Forces of the Philippines Provincial Commander and approved by the Secretary of National Defense.

24) Termination for Convenience

The Procuring Entity, by notice sent to the Contractor, may terminate the Contract, in whole or in part, at any time, if it has determined the existence of any of the following conditions that make contract implementation economically, financially, or technically impractical or unnecessary:

- a) If physical and economic conditions have significantly changed so as to render the project no longer economically, financially, or technically feasible, as determined by the HoPE; or
- b) The HoPE has determined the existence of conditions that make project implementation impractical or unnecessary, such as, but not limited to, fortuitous events, changes in laws and government policies.

25) Termination for Unlawful Acts

The Procuring Entity may terminate the contract in case it is determined prima facie that the Contractor, including any joint venture partner therein, has engaged, before or during the implementation of the contract, in unlawful deeds and behaviors relative to contract acquisition and implementation. These unlawful acts include, but are not limited to, the following:

- a) Corrupt, fraudulent, collusive, coercive, and obstructive practices as defined in **ITB** Clause 3.1, unless otherwise specified in the **SCC**;
- b) Drawing up or using forged documents;
- c) Using adulterated materials, means, or methods, or engaging in production contrary to rules of science or trade; or
- d) Any other act analogous to the foregoing.

26) Termination for Other Causes

26.1 The Procuring Entity may terminate this Contract, in whole or in part, at any time for its convenience. The HoPE may terminate this Contract for the convenience of the Procuring Entity if physical and economic conditions have significantly changed so as to render the project no longer economically, financially, or technically feasible, as determined by the HoPE; or if the HoPE has determined the existence of conditions that make project implementation impractical or unnecessary, such as, but not limited to, fortuitous events, changes in laws and government policies.

26.2 The Procuring Entity or the Contractor may terminate this Contract if the other party causes a fundamental breach of this Contract.

26.3 Other breaches of Contract shall include, but shall not be limited to, the following:

- a) The Contractor stops work for twenty-eight (28) days when no stoppage of work is shown on the current Program of Work and the stoppage has not been authorized by the Procuring Entity;
- b) The Procuring Entity instructs the Contractor to delay the progress of the Works, and the instruction is not withdrawn within twenty-eight (28) days;
- c) A payment certified by the Procuring Entity is not paid to the Contractor within eighty-four (84) days from the date of the Procuring Entity's certificate;

- d) The Procuring Entity gives Notice that failure to correct a particular Defect is a fundamental breach of Contract and the Contractor fails to correct it within a reasonable period of time determined by the Procuring Entity;
 - e) The Contractor does not maintain a Security, which is required; and
 - f) The Contractor has delayed the completion of the Works by the number of days for which the maximum amount of liquidated damages can be paid, as defined in the **GCC** 18.
- 26.4 The Funding Source or the Procuring Entity, as appropriate, will seek the imposition of administrative sanctions as prescribed by RA No. 12009 and without prejudice to the imposition of civil and criminal sanctions as provided under applicable against individuals and organizations deemed to be involved with corrupt, fraudulent, or coercive practices.
- 26.5 When persons from either party to this Contract gives notice of a fundamental breach to the Procuring Entity in order to terminate the existing contract for a cause other than those listed under **GCC** Clause 26.3, the Procuring Entity shall decide whether the breach is fundamental or not.
- 26.6 If this Contract is terminated, the Contractor shall stop work immediately, make the Site safe and secure, and leave the Site as soon as reasonably possible.

27) Procedures for Termination of Contracts

- 27.1 The following provisions shall govern the procedures for the termination of this Contract:
- a) **Verification** - Upon receipt of a written report of acts or causes which may constitute grounds for termination as aforementioned, or upon its own initiative, the End-User or Implementing Unit shall, within a period of seven (7) calendar days, verify the existence of such grounds and cause the execution of a Verified Report, with all relevant evidence attached;
 - b) **Notice to Terminate** - Upon recommendation by the End-User or Implementing Unit, the HoPE shall terminate contracts only by written notice to the Contractor conveying the termination of the contract. The notice shall state:
 - (i) that the Contract is being terminated for any of the grounds aforementioned, and a statement of the acts that constitute the grounds constituting the same;
 - (ii) the extent of termination, whether in whole or in part;
 - (iii) an instruction to the Contractor to show cause as to why this contract should not be terminated; and
 - (iv) special instructions of the Procuring Entity, if any.

The Notice to Terminate shall be accompanied by a copy of the Verified Report;

- c) **Show Cause** - Within a period of seven (7) calendar days from receipt of the Notice of Termination, the Contractor shall submit to the HoPE a verified position paper stating why the contract should not be terminated. If the Contractor fails to show cause after the lapse of the seven (7) day period, either by inaction or by default, the HoPE shall issue an order terminating the contract;
- d) **Rescission of Notice of Termination** - The Procuring Entity may, at any time before receipt of the Contractor's verified position paper, withdraw the Notice to Terminate if it is determined that certain items or works subject of the notice had been completed, delivered, or performed before the Contractor's receipt of the notice;
- e) **Decision** - Within a non-extendible period of ten (10) calendar days from receipt of the verified position paper, the HoPE shall decide whether or not to terminate the contract. It shall serve a written notice to the Contractor of its decision and, unless otherwise provided, the contract is deemed terminated from receipt of the Contractor of the notice of the decision. The termination shall only be based on the grounds stated in the Notice to Terminate.
- f) **Contract Termination Review Committee (CTRC)** - The HoPE may create a committee to assist him in the discharge of its functions under the IRR. All decisions recommended by the CTRC shall be subject to the approval of the HoPE
- g) **Take-over of Contracts** - If a Procuring Entity terminates the contract due to default, insolvency, or for cause, it may enter into a Negotiated Procurement (Take-over of Contracts) pursuant to Section 35.3 of the IRR.
- h) **Notice by Contractor** - The Contractor must serve a written notice to the Procuring Entity of its intention to terminate the contract at least thirty (30) calendar days before its intended termination. The contract is deemed terminated if it is not resumed in thirty (30) calendar days after the receipt of such notice by the Procuring Entity.

27.2 Notwithstanding Section 99 of RA No. 12009 and as provided by applicable laws, the Procuring Entity shall impose on Contractors after the termination of the contract, the penalty of suspension for one (1) year for the first offense, suspension for two (2) years for the second offense from participating in the public bidding process, for violations committed during the contract implementation stage, as stated in the **SCC**.

28) Approval of Drawings and Temporary Works by the Procuring Entity

- 28.1 All Drawings prepared by the Contractor for the execution of the Temporary Works, are subject to prior approval by the Procuring Entity before its use.
- 28.2 The Contractor shall be responsible for design of Temporary Works.
- 28.3 The Procuring Entity's approval shall not alter the Contractor's responsibility for design of the Temporary Works.

28.4 The Contractor shall obtain approval of third parties to the design of the Temporary Works, when required by the Procuring Entity.

29) Acceleration and Delays Ordered by the Procuring Entity

29.1 When the Procuring Entity wants the Contractor to finish before the Intended Completion Date, the Procuring Entity will obtain priced proposals for achieving the necessary acceleration from the Contractor. If the Procuring Entity accepts these proposals, the Intended Completion Date will be adjusted accordingly and confirmed by both the Procuring Entity and the Contractor.

29.2 If the Contractor's Financial Proposals for an acceleration are accepted by the Procuring Entity, they are incorporated in the Contract Price and treated as a Variation.

30) Contractor's Right to Claim

If the Contractor incurs cost as a result of any of the events under **GCC** Clauses 22, 23 and 24 in relation to **GCC** Clause 20, the Contractor shall be entitled to the amount of such cost. If as a result of any of the said events, it is necessary to change the Works, this shall be dealt with as a Variation.

31) Dayworks

31.1 Subject to **GCC** Clause 40 on Variation Order, and if applicable as indicated in the **SCC**, the Contractor shall determine the Dayworks rates to be included or indicated in the Bid. The Dayworks rates in the Contractor's bid shall be used for small additional amounts of work only when the Procuring Entity has given written instructions in advance for additional work to be paid for in that way.

31.2 All work to be paid for as Dayworks shall be recorded by the Contractor on forms approved by the Procuring Entity. Each completed form shall be verified and signed by the Procuring Entity within two (2) days of the work being done.

31.3 The Contractor shall be paid for Dayworks subject to obtaining signed Dayworks forms from both the Procuring Entity and Contractor.

32) Early Warning

32.1 The Contractor shall warn the Procuring Entity at the earliest opportunity of specific likely future events or circumstances that may adversely affect the quality of the work, increase the Contract Price, or delay the execution of the Works.

32.2 The Contractor shall cooperate with the Procuring Entity in making and considering proposals for how the effect of such an event or circumstance can be avoided or reduced by anyone involved in the work and in carrying out any resulting instruction of the Procuring Entity. Should such events or circumstances arise which increase the Contract price or delay the execution of Works, the provisions on variation order shall apply.

33) Program of Work

33.1 Within the time stated in the **SCC**, the Contractor shall submit to the Procuring Entity for approval a Program of Work showing the general methods, arrangements, order, and timing for all the activities in the Works.

- 33.2 An update of the Program of Work shall show the actual progress achieved on each activity and the effect of the progress achieved on the timing of the remaining work, including any changes to the sequence of the activities.
- 33.3 The Contractor shall submit to the Procuring Entity for approval an updated Program of Work at intervals no longer than the period stated in the **SCC**. If the Contractor does not submit an updated Program of Work within this period, the Procuring Entity may withhold the amount stated in the **SCC** from the next payment schedule and continue to withhold this amount until the next payment after the date on which the overdue Program of Work has been submitted.
- 33.4 The Procuring Entity's approval of the Program of Work shall not alter the Contractor's obligations. A revised Program of Work produced by the Contractor shall show the effect of any approved Variations, and shall include all Variations. The Contractor may revise the Program of Work, based on the Variation Order, and submit it to the Procuring Entity again.
- 33.5 When the Program of Work is updated, the Contractor shall provide the Procuring Entity with an updated cash flow forecast. The cash flow forecast shall include different currencies, as defined in the Contract, converted as necessary using the Contract exchange rates.

34) Management Conferences

- 34.1 Either the Procuring Entity or the Contractor may require the other to attend a Management Conference. The Management Conference shall review the plans for remaining work and deal with matters raised in accordance with the early warning procedure.
- 34.2 The Procuring Entity shall record the business of Management Conferences and provide copies of the record to those attending the Conference and to the Procuring Entity. The responsibility of the parties for the actions to be taken shall be decided by the Procuring Entity either at the Management Conference or after the Management Conference. The Procuring Entity shall communicate these responsibilities in writing to all who attended the Conference.

35) Bill of Quantities

- 35.1 The Bill of Quantities shall contain items of work for the construction, installation, testing, commissioning of work, materials, and labor among others, to be done by the Contractor.
- 35.2 The Bill of Quantities is used to calculate the Contract Price. The Contractor is paid for the quantity of the work done at the rate in the Bill of Quantities for each item.
- 35.3 If the final quantity of any work item completed differs from the quantity indicated in the Bill of Quantities, and the difference does not exceed twenty-five percent (25%) of the original quantity for that item, the Procuring Entity shall adjust the Contract accordingly.

This shall be allowed only if the total amount of all such changes does not go beyond ten percent (10%) of the total Contract price, subject to applicable laws, rules, and regulations.

- 35.4 If requested by the Procuring Entity, the Contractor shall provide the Procuring Entity with a detailed cost breakdown of any rate in the Bill of Quantities.

36) Instructions, Inspections and Audits

- 36.1 The Procuring Entity shall at all reasonable times during construction of the Works be entitled to examine, inspect, measure and test the materials and workmanship, and to check the progress of the construction.
- 36.2 If the Procuring Entity instructs the Contractor to carry out a test not specified in the Specification to check whether any work has a defect and the test shows that it does, the Contractor shall pay for the test and any samples. In the absence of any defect, the test shall be a compensation event with no adverse consequences to the contractor.
- 36.3 The Contractor shall permit the Funding Source named in the **SCC** to inspect the Contractor's accounts and records relating to the performance of the Contractor and to have them audited by auditors appointed by the Funding Source, if so required by the Funding Source.

37) Identifying Defects

The Procuring Entity shall check the Contractor's work and notify the Contractor of any defects that are found. Such checking shall not affect the Contractor's responsibilities. The Procuring Entity may instruct the Contractor to check noted defects and test any work that the Procuring Entity considers as substandard and/or defective.

38) Correction of Defects

- 38.1 The Procuring Entity shall give notice to the Contractor of any defects before the end of the Defects Liability Period, which is one (1) year from project completion up to final acceptance by the Procuring Entity.
- 38.2 Every time notice of a defect is given, the Contractor shall correct the notified defect within ninety (90) calendar days from the time the HoPE has issued an order to undertake repair.
- 38.3 The Contractor shall correct the defects which they notice themselves before the end of the Defects Liability Period.
- 38.4 The Procuring Entity shall certify that all defects have been duly corrected.

39) Uncorrected Defects

- 39.1 The Procuring Entity shall give the Contractor at least fourteen (14) days' notice of its intention to use a third party to correct a Defect. If the Contractor does not correct the Defect himself within the period, the Procuring Entity may have the Defect corrected by the third party. The cost of the correction will be deducted from the Contract Price.
- 39.2 The use of a third party to correct defects that are uncorrected by the Contractor will in no way relieve the Contractor of its liabilities and warranties under the Contract.

40) Variation Orders

- 40.1 Variation Orders may be issued by the Procuring Entity to cover any increase or decrease in quantities, including the introduction of new work items that are not included in the original contract or reclassification of work items that are either due to change of plans, design or alignment to suit actual field conditions resulting in disparity between the preconstruction plans used for purposes of bidding and the "as staked plans" or construction drawings prepared after a joint survey by the Contractor and the Government after award of the contract.

Provided, That in case of positive or additive Variation Order/s, the cumulative amount thereof shall not exceed ten percent (10%) of the original contract price; Provided, further, That the scope of works shall not be reduced as to accommodate a positive Variation Order. In all cases, the addition of works under Variation Orders should be within the general scope of the project as bid and awarded.

- 40.2 Any cumulative positive Variation Order beyond ten percent (10%) of the original contract price shall be the subject of another procurement project to be bid out if the Works are separable from the original contract. In exceptional cases where it is urgently necessary to complete the original scope of work, the HoPE, upon the recommendation of the End-User or Implementing Unit, may authorize positive Variation Order/s resulting to a cumulative value of the positive Variation Orders beyond ten percent (10%) but not more than twenty percent (20%) of the original contract price.

All progress payments shall first be charged against the advance payment until the latter has been fully exhausted, at the option of the Procuring Entity.

- 40.3 A Variation Order may either be in the form of a Change Order or Extra Work Order:

- a) A Change Order may be issued by the HoPE or duly authorized representative to cover any increase or decrease in quantities of original work items in the contract.
- b) An Extra Work Order may be issued by the implementing official to cover the introduction of new work necessary for the completion, improvement or protection of the project which was not included as items of work in the original contract, such as, where there are subsurface or latent physical conditions at the site differing materially from those indicated in the contract, or where there are duly unknown physical conditions at the site of an unusual nature differing materially from those ordinarily encountered and generally recognized as inherent in the work or character provided for in the contract.

- 40.4 For Variation Orders, the Contractor shall be paid for additional work items whose unit prices shall be derived based on the following:

- a) For additional or extra works duly covered by Change Orders involving work items which are exactly the same or similar to those in the original contract, the applicable unit prices of work items original contract shall be used.

- b) For additional or extra works duly covered by Extra Work Orders involving new work items that are not in the original contract, the unit prices of the new work items shall be based on the direct unit costs used in the original contract (e.g., unit cost of cement, rebars, form lumber, labor rate, equipment rental, etc.). All new components of the new work item shall be fixed prices; Provided, The same is acceptable to both the Government and the Contractor; Provided further, That the direct unit costs of new components shall be based on the Contractor's estimate as validated by the Procuring Entity concerned via documented canvass in accordance with existing rules and regulations. The direct cost of the new work item shall then be combined with the mark-up factor (i.e., taxes and profit) used by the Contractor in its bid to determine the unit price of the new work item.

40.5 Under no circumstances shall a Contractor proceed to commence work under any Change Order or Extra Work Order unless it has been approved by the HoPE or its duly authorized representative. However, under any of the following conditions, the Procuring Entity's representative or Project Engineer may, subject to the availability of funds and within the limits of its delegated authority, allow the immediate start of work under any Change Order or Extra Work Order:

- a) In the event of an emergency where the prosecution of the work is urgent to avoid detriment to public service, or damage to life and/or property; and/or
- b) When time is of the essence;

Provided, however, That such approval is valid on work done up to the point where the cumulative increase in value of work on the project which has not yet been duly fully approved does not exceed five percent (5%) of the adjusted original contract price.

Provided, further, That immediately after the start of work, the corresponding Change Order or Extra Work Order shall be prepared and submitted for approval in accordance with the abovementioned rules. Payments for Works satisfactorily accomplished on any Change Order or Extra Work Order may be made only after approval of the same by the HoPE or its duly authorized representative.

Provided, finally, That for a Change Order or Extra Work Order involving a cumulative amount exceeding five percent (5%) of the original contract price, no work thereon may be commenced unless said Change Order or Extra Work Order has been approved by the HoPE or its duly authorized representative.

41) Contract Completion

Once the project reaches an accomplishment of ninety-five percent (95%) of the total contract amount, the Procuring Entity may constitute an inspectorate team to conduct preliminary inspection and submit a punch-list to the Contractor in preparation for the final turnover of the project. Said punch-list will contain, among others, the remaining Works, Work deficiencies for necessary corrections, and the specific duration/time to fully complete the project within the approved remaining contract time. This, however, shall not preclude the claim of the Procuring Entity for liquidated damages, if applicable.

42) Suspension of Work

- 42.1 The Procuring Entity shall have the authority to suspend the work wholly or partly by written order for such period as may be deemed necessary, due to *force majeure* or any fortuitous event or for failure on the part of the Contractor to correct bad conditions which are unsafe for workers or for the general public, to carry out valid orders given by the Procuring Entity or to perform any provisions of the contract, or due to adjustment of plans to suit field conditions as found necessary during construction. The Contractor shall immediately comply with such order to suspend the work wholly or partly.
- 42.2 The Contractor or its duly authorized representative shall have the right to suspend work operation on any or all projects or activities along the critical path of activities after fifteen (15) calendar days from date of receipt of written notice from the Contractor to the district engineer, regional director, consultant or equivalent official, as the case may be, due to the following:
- a) There exist right-of-way problems which prohibit the Contractor from performing work in accordance with the approved construction schedule.
 - b) Requisite construction plans which must be owner furnished are not issued to the Contractor precluding any work called for by such plans.
 - c) Peace and order conditions that make it extremely dangerous, if not possible, to work. However, this condition must be certified in writing by the Philippine National Police station which has responsibility over the affected area and confirmed by the Department of the Interior and Local Government (DILG) Regional Director.
 - d) There was a failure on the part of the Procuring Entity to deliver government-furnished materials and equipment as stipulated in the contract.
 - e) Delay in the payment of Contractor's claim for progress billing beyond forty-five (45) calendar days from the time the Contractor's claim has been certified by the Procuring Entity's authorized representative that the documents are complete, unless there are justifiable reasons for the delay in payment which shall be communicated in writing to the Contractor.
- 42.3 In case of total suspension, or suspension of activities along the critical path, which is not due to any fault of the Contractor, the elapsed time between the effectivity of the order suspending operation and the order to resume work shall be allowed to the Contractor by adjusting the contract time accordingly.

43) Payment on Termination

- 43.1 If the Contract is terminated because of a breach of Contract by the Contractor, the Procuring Entity shall issue a certificate for the value of the work done and Materials ordered less advance payments received up to the date of the issue of the certificate, and less the percentage to apply to the value of the work not completed, as indicated in the **SCC**. Additional liquidated damages shall not apply. If the total amount due to the Procuring Entity exceeds any payment

due to the Contractor, the difference shall be a debt payable to the Procuring Entity.

- 43.2 If the Contract is terminated for the Procuring Entity's convenience, or due to a breach of Contract by the Procuring Entity, the Procuring Entity shall issue a certificate for the value of the work done, Materials ordered, the reasonable cost of removal of Equipment, repatriation of the Contractor's personnel employed solely on the Works, and the Contractor's costs of protecting and securing the Works, and less advance payments received up to the date of the certificate.
- 43.3 The net balance due shall be paid or repaid within twenty-eight (28) days from the notice of termination.
- 43.4 If the Contractor has terminated the Contract under **GCC** Clauses 23 to 24, the Procuring Entity shall promptly return the Performance Security to the Contractor.

44) Extension of Contract Time

- 44.1 Should the amount of additional work or other special circumstances warrant the entitlement of the Contractor to an extension of contract time, the Procuring Entity shall determine the amount of such extension; Provided, That the Contractor has notified the Procuring Entity of its claim for extension of contract time prior to the expiration of the contract time, and within thirty (30) calendar days after the additional work has been commenced or the circumstances leading to such claim have arisen, as the case may be, in order to give the Procuring Entity the opportunity to investigate the claim. Failure to provide such notice shall constitute a waiver of such a claim by the Contractor. Upon receipt of full and detailed particulars, the Procuring Entity shall examine the facts and extent of the delay and shall extend the contract time to complete the contract work when, in the Procuring Entity's opinion, the findings of facts justify an extension.
- 44.2 No extension of contract time shall be granted to the Contractor due to ordinary unfavorable weather conditions and inexcusable negligence of the Contractor to provide the required equipment, supplies, or materials.
- 44.3 Extension of contract time may be granted only when the affected activities fall within the critical path of the PERT, CPM, Precedence Diagram Method or any other project management tool.
- 44.4 No extension of contract time shall be granted when the reason given to support the request for extension was already considered in the determination of the original contract time during the conduct of detailed engineering and in the preparation of the contract documents as agreed upon by the parties before contract perfection.
- 44.5 Extension of contract time may be granted in the cases indicated in the **SCC**.
- 44.6 The written consent of the bank, or surety or insurance company, as the case may be, must be attached to any request of the Contractor for extension of contract time and submitted to the Procuring Entity for consideration and the validity of the Performance Security shall be correspondingly extended.

- 44.7 The Procuring Entity shall extend the Intended Completion Date if a Variation is issued which makes it impossible for the Intended Completion Date to be achieved by the Contractor without taking steps to accelerate the remaining work, which would cause the Contractor to incur additional costs. No payment shall be made for any event which may warrant the extension of the Intended Completion Date.
- 44.8 The Procuring Entity shall decide whether and by how much to extend the Intended Completion Date within twenty (20) days of the Contractor asking the Procuring Entity for a decision thereto after fully submitting all supporting information. If the Contractor has failed to give early warning of a delay or has failed to cooperate in dealing with a delay, the delay by this failure shall not be considered in assessing the new Intended Completion Date.

45) Price Escalation

In the event of an extraordinary increase in prices of specific components of the Infrastructure Project, price escalation may be considered, subject to prior approval of the GPPB. If the cost of construction components increases by more than ten percent (10%) of the unit price of work items, as determined against the prevailing price indices of the PSA, a price escalation may be authorized at a no-loss, no-gain basis, using the appropriate formula prescribed by the GPPB. For the purpose of this Section, the PSA shall ensure that its price indices are region-specific and updated on a monthly basis

46) Completion

The Contractor shall request the Procuring Entity to issue a Certificate of Completion of the Works, and the Procuring Entity will do so upon determining that the work is completed.

47) Taking Over

The Procuring Entity shall take over the Site and the Works within seven (7) days from the date of issuance of a Certificate of Completion; Provided, That it shall not release the Contractor of its responsibilities within the defects liability period.

48) Operating and Maintenance Manuals

- 48.1 If "as built" Drawings and/or operating and maintenance manuals are required, the Contractor shall supply them by the dates stated in the **SCC**.
- 48.2 If the Contractor does not supply the Drawings and/or manuals by the dates stated in the **SCC**, or they do not receive the Procuring Entity's approval, the Procuring Entity shall withhold the amount stated in the **SCC** from payments due to the Contractor.

Section V. Special Conditions of Contract

Special Conditions of Contract

GCC Clause	
1.1	The Intended Completion Date is Three Hundred Sixty-Five (365) Calendar days from the date of issuance of Notice to Proceed (NTP).
1.2	The Procuring Entity is Bureau of Corrections, National Headquarters, NBP Reservation, Poblacion, Muntinlupa City.
1.3	The Site is located at Iwahig Prison and Penal Farm (IPPF), Puerto Princesa City, Palawan.
1.4	The Start Date is from the date of issuance of Notice to Proceed (NTP).
1.5	The Works consist of <ol style="list-style-type: none"> 1. One (1) Unit 3-Storey “Type B” PDL Dormitory. 2. Partition Fence 3. Electrical System. 4. Fire Protection System 5. Fire Detection and Alarm System 6. Water Supply System 7. Sanitary, Drainage and Vent Systems 8. Site development 9. Roadworks 10. Waterproofing Works
5.1	The Procuring Entity shall give possession of all parts of the Site to the Contractor from the date of issuance of Notice to Construct.
6.5	The Contractor shall employ the following Key Personnel: <i>[List key personnel by name and designation]</i>
7.1	No further instructions.
8.1	The amount of the advance payment is Five Percent (5%) of the contract price , to be made in two installments (2.5% upon issuance of Notice to Proceed and 2.5% upon issuance of Notice to Construct).
9.1	No further instructions.
9.4	All progress payments shall first be charged against the advance payment until the latter has been fully exhausted, at the option of the Procuring Entity.

	The first progress payment may be paid by the Procuring Entity to the Contractor; Provided, that at least Fifty Percent (50%) of the Works has been accomplished as certified by the Procuring Entity.
12.7	No further instructions.
13.1	The site investigation reports are: <i>[list here or state none]</i>
15.3	No further instructions.
15.5	Fifteen (15) years.
19.2	The Arbitrator is the person appointed jointly by the Procuring Entity and the Contractor: CIAC
20	“All partners to the joint venture shall be jointly and severally liable to the Procuring Entity.”
25(a)	No further instructions.
27.2	<p>a) Failure of the Contractor, due solely to its fault or negligence, to mobilize and start work or performance within the specified period in the Notice to Proceed (“NTP”);</p> <p>b) Failure by the Contractor to fully and faithfully comply with its contractual obligations without valid cause, or failure by the Contractor to comply with any written lawful instruction of the Procuring Entity or its representative(s) pursuant to the implementation of the contract. For the procurement of infrastructure projects or consultancy contracts, lawful instructions include but are not limited to the following:</p> <ul style="list-style-type: none"> i) Employment of competent technical personnel, competent engineers and/or work supervisors; ii) Provision of warning signs and barricades in accordance with approved plans and specifications and contract provisions; iii) Stockpiling in proper places of all materials and removal from the project site of waste and excess materials, including broken pavement and excavated debris in accordance with approved plans and specifications and contract provisions; iv) Deployment of committed equipment, facilities, support staff and manpower; and v) Renewal of the effectivity dates of the performance security after its expiration during the course of contract implementation. <p>c) Assignment and subcontracting of the contract or any part thereof or substitution of key personnel named in the proposal without prior written approval by the Procuring Entity.</p> <p>d) Poor performance by the Contractor or unsatisfactory quality and/or progress of work arising from its fault or negligence as</p>

	<p>reflected in the CPES rating sheet. In the absence of the CPES rating sheet, the existing performance monitoring system of the Procuring Entity shall be applied. Any of the following acts by the Contractor shall be construed as poor performance:</p> <p>i) Negative slippage of fifteen (15%) and above within the critical path of the project due entirely to the fault or negligence of the Contractor; and</p> <p>ii) Quality of materials and workmanship not complying with the approved specifications arising from the Contractor's fault or negligence.</p> <p>e) Willful or deliberate abandonment or non-performance of the project or contract by the Contractor resulting to substantial breach thereof without lawful and/or just cause.</p> <p>In addition to the penalty of suspension, the performance security posted by the Contractor shall also be forfeited.]</p>
31.1	Dayworks are applicable at the rate shown in the Contractor's original Bid.
33.1	The Contractor shall submit the Program of Work to the Procuring Entity within fourteen (14) calendar days of delivery from the Notice of Award.
33.3	<p>The period between Program of Work updates is Thirty (30) calendar days.</p> <p>The amount to be withheld for late submission of an updated Program of Work is one tenth of one percent of the total contract price.</p>
36.3	The Funding Source is the Government of the Philippines.
43.1	The percentage to apply to the value of the work not completed is <i>[insert percentage]</i> .

44.5	<p>a) rainy/unworkable days considered unfavorable for the prosecution of the Works at the site, based on the actual conditions obtained at the site, in excess of the number of rainy/unworkable days pre-determined by the Procuring Entity in relation to the original contract time during the conduct of detailed engineering and in the preparation of the contract documents as agreed upon by the parties before contract perfection, and/or</p> <p>b) major calamities such as exceptionally destructive typhoons, floods and earthquakes, and epidemics,</p> <p>c) delays attributable to the Procuring Entity, such as non-delivery on time of materials, working drawings, or written information to be furnished by the Procuring Entity, non-acquisition of permit to enter private properties or non-execution of deed of sale or donation within the right-of-way resulting in complete paralyzation of construction activities, and</p> <p>d) other meritorious causes as determined by the Procuring Entity and approved by the HoPE such as shortage of construction materials, general labor strikes, and peace and order problems that disrupt construction operations through no fault of the Contractor may be considered as additional grounds for extension of contract time provided they are publicly felt and certified by appropriate government agencies such as DTI, DOLE, DILG, and DND, among others.</p>
48.1	<p>The date by which operating and maintenance manuals are required is upon actual turn-over.</p> <p>The date by which “as built” drawings are required is upon actual completion of the project.</p>
48.2	<p>The amount to be withheld for failing to produce “as built” drawings and/or operating and maintenance manuals by the date required is equivalent to one percent (1%) of the contract price.</p>

Section VI. Specifications

TERMS OF REFERENCE

DESIGN AND BUILD OF BUCOR REGIONAL FACILITY ONE (1) UNIT 3- STOREY TYPE B DORMITORY – PHASE 5

Iwahig Prison and Penal Farm, Puerto Princesa City, Palawan

1. PROJECT INFORMATION

1.1. Project Background

The Bureau of Corrections continues to implement its regional infrastructure modernization program to improve custodial management, institutional security, and living conditions for Persons Deprived of Liberty (PDLs). As part of Phase 5, the project involves the design and construction of One (1) unit, Three-Storey Type B Dormitory within the existing 10-hectare regional facility, maximizing the use of the available land while addressing current accommodation needs.

The Type B Dormitory will provide secure, humane, and adequately ventilated living quarters for medium- and minimum-security PDLs, in compliance with prescribed correctional standards on space allocation, sanitation, safety, and structural integrity. The dormitory will also include essential utilities such as water, electricity, drainage, and common support facilities to ensure operational efficiency.

Implemented under a Design and Build scheme, the project integrates architectural and engineering planning with construction execution, covering site development, foundation and structural works, installation of utilities, and completion of all fixtures and finishes using durable, climate-appropriate materials. Upon completion, the dormitory will enhance accommodation capacity, reduce congestion, improve custodial management, and support the overall modernization and sustainability objectives of BuCor's regional facility.

1.2. Project Description

The Bureau of Corrections (BuCor), as the primary government agency responsible for the custody, rehabilitation, and reformation of Persons Deprived of Liberty (PDLs) with Three (3) years and 1 day sentence, is undertaking the Design and Build of BuCor Regional Facility – One (1) Unit, 3-Storey Type B Dormitory – Phase 5 (IPPF) in Puerto Princesa City, Palawan. This project is a strategic component of BuCor's broader mandate to modernize penal institutions and implement decentralized correctional management systems across the Philippines.

The establishment of the BuCor Regional Prison Facility at IPPF seeks to address critical challenges in the country's penal system, including severe congestion at the New Bilibid Prison (NBP), the logistical burdens of centralized operations, and the limited regional access to rehabilitative services. Through

this initiative, BuCor aims to create a correctional environment that upholds security, dignity, and restorative justice, in accordance with national standards and international human rights principles.

As the implementing agency, BuCor shall ensure that the facility is designed and constructed to support its operational goals and custodial standards.

BuCor's leadership in this project ensures that the facility will not only serve as a place of incarceration but also as a center for rehabilitation, skills development, and reintegration. The design shall incorporate sustainable and climate-resilient features, ensure proper segregation of PDLs by security classification, and provide humane living conditions that meet the evolving standards of penology and custodial care.

Through this project, BuCor reaffirms its commitment to institutional transformation—ensuring that correctional facilities across the country are safe, rehabilitative, and regionally responsive to the needs of PDLs and correctional personnel alike.

The project will adopt a Design and Build scheme, wherein the contractor is responsible for both the comprehensive detailed design and actual construction of the facility. The total project duration is **Three Hundred Sixty-Five (365) Calendar Days (12 Months)**, inclusive of the preparation of plans, securing necessary permits, and full completion of civil works.

The plans and designs shall be in accordance with the plan of the said structures as conceptualized by the Planning and Design Division (PDD) under the Directorate for Engineering Services (DES) or as conceptualized by the winning bidder if the latter is found to be superior (as defined in Section 3.1.1 of this TOR).

The Design and Build of BuCor Regional Facility – One (1) Unit, 3-Storey Type B Dormitory – Phase 5 (IPPF shall be constructed as per approved drawings, specifications, bill of materials, scope of works and the general contract conditions following the guidelines in accordance to the Rule II, Section 8 of the IRR of R.A. 12009 or the New Government Procurement Act.

The project shall have the following basic components:

- 1.1.1. Complete Detailed Architectural and Engineering Design Plans, technical specifications, and design calculations for the construction of the Project.

Such plans, designs, and technical specifications shall be subject for review and approval by the Head of Procuring Entity (HOPE). The Design Development and the Contract Documents phases of the design shall continue after the bid is awarded. It shall likewise be subject for review and recommending approval by the BuCor - NHQ Directorate for Engineering Services.

1.1.2. The bid shall be based on the conceptual/schematic design drawings prepared by the BuCor PDD or that submitted by the winning bidder as defined in Section 3.1.1 of this TOR.

1.1.3. The Contractor shall complete the construction of the following facility component:

1.1.3.1. One (1) Unit 3-Storey "Type B" PDL Dormitory (20x110) with 50 cells design capacity of 500 PDL with 250 units Double Decker Bed Bunks; (see 9.1.4 Type B Dormitory conceptual plan)

1.1.3.2. Partition Fence: with 3 sets of 600mm dia. Concertina/Barb wire steel matting fence with sliding steel control gate with wicket gate. Provided and additional angle bar support and 4 sets of steel bar to reinforce the concertina wires. To include 200w integrated solar street lights every 25 meters and to include Gates; (see 9.1.3 Partition Fence Conceptual Plan).

1.1.3.3. Electrical System: Three phase power supply (shall be tapped from the nearest existing distribution or network/source) includes piping, wirings, fixture, panel boards, circuit breakers, including step down distribution transformers, automatic transfer switch, enclosed circuit breaker and all other necessary item to complete the system.

With Backup Power (Three-Phase Genset) supply system with capacity not less than total computed MVA load, without demand factor (designed to supply the entire compound including the future developments), and to include Capacitor Bank, if necessary;

1.1.3.4. Fire Protection System: includes piping, sprinklers, Fire & Jockey Pump, Pump house, Fire Tank, Fire Suppression equipment and all other necessary item to complete the system;

1.1.3.5. Fire Detection and Alarm System: includes piping, wiring, smoke and heat detector and all other necessary item to complete the system;

1.1.3.6. Water Supply System: Provision of a complete water supply system capable of delivering potable water at sufficient pressure.

Scope includes all required piping, plumbing fixtures, Pumps Cistern Tank, and an overhead water tank, with connection (tap-in) to the existing water supply source, and all other necessary components for the full completion and operational functionality of the system;

1.1.3.7. Sanitary, Drainage and Vent Systems: Includes all sanitary and drainage piping, Perimeter Catch Basin, Septic Tank installation (to be tapped to the nearest existing point of discharge), and all other necessary components required to complete the system;

1.1.3.8. Site development: Includes Grading and Earthwork levelling the ground and shaping it to the required specifications for the construction project. This may involve excavation, filling and compacting soil;

1.1.3.9. Roadworks: including site preparation, earthworks, construction of sub-base and base layers, concrete pavement;

1.1.3.10. Waterproofing Works: Includes the application of an appropriate waterproofing system at the second-floor toilet, roof deck toilet, and the entire roof deck area.

1.2. Contractual Framework

The implementation of the Design and Build of BuCor Regional Facility – One (1) Unit, 3-Storey Type B Dormitory – Phase 5 (IPPF) in Puerto Princesa City, Palawan (IPPF) shall be governed under a Design and Build Contract, wherein a single contractor shall assume full responsibility for both the detailed design and construction of the facility within a fixed period of Three hundred Sixty-Five (365) Calendar Days (12 Months) from the issuance of the Notice to Proceed (NTP).

This contractual arrangement ensures a streamlined process by integrating planning, design, and construction into one contract, which shall reduce procurement timelines, minimize cost variations, and promote accountability in the delivery of outputs. The contractual obligations, deliverables, and timelines shall be clearly defined in accordance with applicable laws, rules, and regulations, specifically the following:

- Republic Act No. 12009 – New Government Procurement Act and Implementing Rules and Regulations (IRR)
- National Building Code of the Philippines (PD 1096) and related codes and standards
- BuCor Design Standards and Guidelines for Correctional Facilities Relevant provisions of RA 10575, Rule VII (The Bureau of Corrections Act of 2013)
- Applicable environmental and safety regulations

The contract shall be lump-sum, fixed price, and turnkey in nature, with clearly defined milestones and deliverables that include but are not limited to:

- Preliminary and Detailed Engineering Design (subject to BuCor's approval)
- Preparation and acquisition of all necessary permits and clearances
- Execution of site development and construction works
- Provision of equipment and utilities as required in the approved plans
- Final testing, commissioning, and turnover of the completed facility to BuCor

All designs, specification, BOM and scope of work must be approved by BuCor prior to the commencement of construction activities. Progress billing shall be based on approved accomplishments corresponding to the work schedule and milestone completion, as certified by the BuCor Planning and Design Division under the Directorate for Engineering Services

The contractor shall also be required to submit the following contractual safeguards:

- Performance Security
- Warranty Security/Surety Bond
- Contractor's All Risk Insurance (CARI)
- Environmental Compliance Certificate (ECC), if applicable

BuCor, as the implementing agency, shall designate a Project Inspectorate Team (PIT) to monitor compliance with the technical specifications, construction schedule, quality standards, and overall project performance, and shall serve as the final authority in validating project outputs.

2. SCOPE OF CONTRACT

2.1. OBLIGATIONS OF THE WINNING BIDDER/CONTRACTOR

2.1.1. Presentation of conceptual design (including perspective, walkthrough, innovations and sustainability) for the project;

2.1.2. Render architectural and allied engineering design services including final schematic design necessary for the implementation of the Project. The allied engineering design services shall include, but shall not be limited to, design for architectural, civil, electrical, and plumbing. All drawings shall be generated using modern modeling/drafting software and printed on High Quality 20" x 30" blue print paper;

2.1.3. Undertake Detailed Architectural and Engineering Designs (DAEDs) using the given data such as topographic, hydrographic and cross-section surveys, geotechnical and geological investigation, and hydrologic investigation and initial schematic design or design concept provided by the BuCor PDD which conforms with the Minimum Performance Specifications and Standards (MPSS);

2.1.4. Secure environmental clearance or an “Environmental Compliance Certificate (ECC)”. If applicable, the proposed project is considered outside the purview of the Philippine Environmental Impact Statement (EIS) System, a Certificate of Non-Coverage or Certificate of Exemption shall be secured indicated. Refer to *EMB Memorandum Circular 005-2014 -Revised Guidelines for Coverage Screening and Standardized Requirements under the Philippine EIS System*;

2.1.5. Construct the project according to the DAEDs prepared by the Winning Bidder and approved by the BuCor and in compliance with the MPSS as well as provided in Rule VII, Section 7 of the Revised IRR of RA 10575. Likewise, construction includes conformance to the provisions pertaining to buildings under the latest edition of the DPWH Standard Specifications for Public Works Structures, Volumes II and III (Blue Book). The Blue Book prescribes, among other things, the material requirements and construction requirements for different items of work, including the tests to be conducted during construction by the DPWH-accredited testing laboratory. The Blue Book incorporates pertinent provisions of the American Society for Testing and Materials (ASTM) and American Concrete Institute (ACI), among other standards, pertaining to construction. Attention shall be given to the relevant items of work in the following Parts of the Blue Book:

2.1.5.1. Volume II

- Part A – Facilities for the Engineer
- Part B – Other General Requirement

2.1.5.2. Volume III

- Part A – Earthwork
- Part B – Plain and Reinforced Concrete Works
- Part C – Finishing
- Part D – Electrical
- Part E – Mechanical
- Part I – Water Supply
- Part J – Flood Control and Drainage
- Part I-C – Drainage Works

2.1.6. Submit a certification from a recognized foreign or international institution to the effect that the new materials or technology meets the MPSS for this Project and has been successfully used in existing structures with proven integrity, or if the Proponent intends to use any new material/technology that is not accredited by the DPWH Bureau of Research and Standards (BRS).

2.1.7. Perform Actual Survey and Staking, Site Investigation and Soil Investigation to obtain on site actual condition;

- 2.1.8. The Winning Bidder or Contractor shall be solely responsible for the design and shall be held responsible for any default resulted from improper design. Further, extended liability of the contractor since it stipulated that the works, when completed, shall be fit for the purpose for which it was intended as defined in the contract;
- 2.1.9. The Winning Bidder or Contractor shall be held liable for design and structural defects and/or failure of the completed project within the warranty period specified in Rule XVIII Section 90 paragraph 90.2 of R.A. 12009.
- 2.1.10. The winning bidder/contractor shall have a Construction Safety and Health Program approved by the Safety Officer of PDD designed for the proposed project (if the winning bidder/contractor will be using the PDL as an additional work force for the project).
- 2.1.11. The winning bidder/contractor shall certify that he has, at his own expense, inspected and examined the proposed project site, its surroundings and existing infrastructure and facilities related to the execution of the work and has obtained all the pieces of information that are considered necessary for the proper execution of the work covered under these Terms of Reference.

2.2. OBLIGATIONS OF THE BUCOR

- 2.2.1. Provide full information on all requirements for the Project;
- 2.2.2. Approve the Winning Bidder or Contractor's design without diminishing their full and sole responsibility for the quality and integrity thereof;
- 2.2.3. Give prompt written notice thereof to Winning Bidder or Contractor, if it observes or becomes aware of any defect in the Project;
- 2.2.4. Designate, when necessary, representatives authorized to act on its behalf. It shall examine documents submitted by the Winning Bidder or Contractor and render decisions pertaining thereto promptly, to avoid unreasonable delay in the progress of their work. Likewise, observe the procedure of issuing orders to the Winning Bidder or Contractor;
- 2.2.5. Conduct regular coordination meeting between the winning bidder or contractor to facilitate the implementation of the project.
- 2.2.6. Assist in the coordination of the winning bidder or contractor with various utility agencies during the detailed design and implementation of the project.
- 2.2.7. Supervise and monitor the implementation of the project;

2.2.7.1. Construction Monitoring and Testing Forms:

- The use of Construction Monitoring and Testing Forms that will be provide by the BuCor-NHQ PDD is mandatory throughout the duration of construction;
- Oversight of these forms will be conducted by the Engineering Services (ES) of the IPPF on behalf of the BuCor PDD;
- IPPF-ES to impose to Contractor testing of all items after installation and/or application. ES to send PDD copy of the test report/s;
- IPPF-ES to monitor material delivery of Contractor to ensure all materials installed and/or applied are in accordance with the specifications stated on plans and contract of this project;
- In case, there would be substitute or alternative to the original specification of material/s, IPPF-ES to inform PDD of such variation.

2.2.7.2. BuCor Engineer Visits:

- NHQ engineers and architects (personnel of PDD) will conduct site visits on a quarterly basis or whenever deemed necessary to ensure compliance with standards and regulations;
- PDD Personnel to witness the Final Testing and Commissioning of the Systems, Equipment and Utilities prior to Acceptance of the project or part of the project thereof.

2.2.7.3. Progress Billing Payment:

- IPPF ES engineers will provide weekly/monthly updates, or as deemed necessary, on the Statement of Work accomplishment based on the actual progress of the project, including reports update.

2.2.8. Pay the accomplishment accepted in the conformance with the MPSS included under the Design and Build Contract.

- 2.2.8.1. This reports and Statement of Work Accomplishment (SWA) updates of the IPPF ES will be assessed by PDD-NHQ prior to any progress billing payments being made.

2.3 BIDDING DOCUMENTS

Please refer to the Implementing Rules and Regulations (IRR) of Republic Act (RA) No. 12009 and the Philippine Bidding Documents for Infrastructure Projects, First Edition (May 2025).

3. SCOPE OF WORKS

The Scope of Work covers the complete design and construction of the Design and Build of BuCor Regional Facility – One (1) Unit, 3-Storey Type B Dormitory – Phase 5 at Iwahig Prison and Penal Farm (IPPF), including all planning, permitting, site development, building construction, utility installation, and necessary support systems to ensure a fully functional correctional institution. The project shall be completed within Four Hundred Fifty-Five (365) Calendar Days (12 Months) from the issuance of the Notice to Proceed (NTP).

3.1. PLANNING AND DESIGN PHASE

3.1.1. Preliminary Architectural Plan (PAP) by Bidder

The approved concept design shall adopt the provisions indicated *in Rule VII, Section 7 of the Revised IRR of RA 10575*.

The winning bidder/contractor shall submit also an alternative design concept with respect to the actual site condition. This alternative design by the winning bidder/contractor shall be adopted the same be found to be superior than the one conceptualized by the BuCor PDD.

The contractor shall undertake all activities necessary to produce complete, coordinated, and approved design documents for the project. This includes:

3.1.1.1 Site Assessment and Investigation

- Topographic and geotechnical surveys
- Environmental and accessibility analysis
- Coordination with local authorities and BuCor representatives

3.1.1.2 Architectural and Engineering Design

- Master planning and site development
- Detailed architectural, civil, structural, sanitary, plumbing, and electrical designs
- Landscape and perimeter design
- Climate-resilient and sustainable design features

3.1.1.3 Preparation of Detailed Plans and Specification

- Construction drawings, technical specifications, and bills of quantities
- Material and equipment specifications
- Design compliance with BuCor and national standards

3.1.1.4 Design Review and Approval

- Submission of design documents for BuCor review
- Incorporation of comments and final approval before construction

3.1.2. Detailed Architectural and Engineering Design (DAED) by the Winning Bidder

During the implementation of the Project, the Winning Bidder shall prepare the Design Architectural and Engineering Design (DAED) of the Project and submit the same to the BuCOR for approval prior to the execution of the construction works.

The Winning Bidder shall prepare the Design Architectural and Engineering Design (DAED) based on its Preliminary Architectural Plan (PAP) as reviewed and accepted by the BuCor PDD and in accordance with the Minimum Performance Standards and Specifications (MPSS). The DAED shall be undertaken with a degree of accuracy that will allow estimates to be made within approximately plus or minus five percent (+/-5%) of the final quantities.

Once approved by the BuCor, the Winning Bidder's DAED shall form part of the MPSS. The BUCOR-approved DAED, together with the MPSS provisions on Construction shall base on *Rule VII Section 8 of the IRR of R.A. 12009*, shall govern the actual Construction undertaken by the Winning Bidder.

The Winning Bidder shall undertake the necessary a schedule of detailed engineering activities (survey and investigation) in accordance with the DPWH Design Guidelines, Rule VII of Revised IRR of R.A. 10575 and IRR of RA 12009 Section 8.2.1 and 8.3. In carrying out these works, the winning bidder must guarantee that all aspects of the project's engineering and environmental considerations are thoroughly addressed, especially during the initial site investigations and when creating the preliminary and final detailed engineering plans.

The Winning Bidder shall ensure that all designs submitted for approval have fully taken into account key findings from the engineering, environmental, and that negative environmental impacts have been minimized or eliminated to the fullest extent possible.

3.1.3. Architectural and Engineering Design Submittals

3.1.3.1. Architectural Design

- The building shall be designed in compliance with building standards, incorporating structural and electrical systems, natural or combined ventilation and lighting, and ensuring the safety and security of personnel and PDL.
- The prospective bidder shall prepare the Preliminary Architectural Plans in accordance with the requirements of the National Building Code of the Philippines, Accessibility Law (BP 344) including all other applicable laws and local ordinances.

SUBMITTALS: (at suitable scale on high quality 20" x 30" blue print paper minimum size)

- Site Development Plan
- Vicinity Map
- Perspective
- Floor Plans
- Elevations
 - Front Elevation
 - Rear Elevation
 - Right Elevation
 - Left Elevation
- Sections
 - Longitudinal Section
 - Cross Section
- Doors & Window Schedule
- Plans and details of stairs and ramps
- Schedule of Finishes for floors, walls and ceiling
- Miscellaneous Details
- Others as applicable

3.1.3.2. Structural Design

- The proponent shall prepare the necessary structural analysis/calculation and design of the structural members of the building component in accordance with the National Building Code of the Philippines with its referral codes such as the latest National Structural Code of the Philippines.

The design for the structure shall take into account, among other things, the seismic requirements of the area to determine the optimum safety of the whole structure and to minimize possible earthquake damage.

- On the basis of the data obtained from the detailed site investigations, topographical/soil and survey, geotechnical engineering, foundation investigation, material testing, survey of existing site conditions, the seismic requirements of the area, the load requirements of the building and other investigation required to obtain the data necessary to ensure the safety of the structure, the proposal shall prepare the preliminary structural design plans of the structure.

SUBMITTALS: (at suitable scale on high quality 20" x 30" blue print paper minimum size)

- Structural Design Criteria and Design Notes
- Structural Analysis
- Foundation Plan
- Floor framing plans
- Schedule of slab, beams and girders
- Schedule of columns
- Schedule of footings
- Structural details of stairs/ramp, if applicable
- Roof framing plan, if applicable
- Schedule and details of trusses, if applicable
- Road Design and details (if applicable)
- Structural Methodology
- Miscellaneous Details
- Others as applicable

3.1.3.3. Sanitary/Plumbing Design

3.1.3.3.1. General

- The detailed design shall conform to the general standards adopted by the Sanitary & Plumbing Code of the Philippines and other pertinent laws and ordinances.
- All design considerations/assumptions shall be based on the results of the technical studies, detailed analyses, and design computations.
- The technical drawings and specifications shall clearly indicate all the details required to ascertain the care and thoroughness devoted in the preparation of the drawings.

3.1.3.3.2. Drainage and Sewerage

- The drainage layout shall show all the required information such as direction of flow, manhole-to-manhole distances, and sizes of lines, manholes/canals, location of outfalls, etc.

SUBMITTALS: (at suitable scale on high quality 20" x 30" blue print paper minimum size)

- General Notes
- Legend & Symbols
- Sewer, vent and storm drainage layout
- Blow-up toilet plan for Cell, Post Tower, Male and Female
- Isometric Diagram
- Schematic Diagram
- Miscellaneous details
- Drainage and sewerage System
- Three Chamber Septic Tank plans and details
- Others as applicable

3.1.3.3.3. Water Supply and Distribution System

- The Proponent shall carry out a preliminary detailed design for the water supply of the project. The design should be on the basis of the source and volume of water supply, water consumption, piping network, and conveyance in accordance with the applicable laws, rules and regulations governing health, safety and sanitation.

SUBMITTALS: (at suitable scale on high quality 20" x 30" blue print paper minimum size)

- General Notes
- Legend & Symbols
- Water Line layout
- Water Line Isometric Diagram
- Water line schematic Diagram
- Blow-up toilet plan for Cell, Post Tower, Male and Female
- Water Reservoir Plans and details
- Miscellaneous details
- Others as applicable

3.1.3.4. Electrical Design

- The prospective bidder shall prepare a preliminary design plan for the electrical and power supply system of the building in

accordance with the Electrical Code of the Philippines, Fire Code of the Philippines, National Building Code of the Philippines and other relevant laws and ordinances.

- The prospective bidder shall prepare a design for the electrical and power supply system considering ease of maintenance and prevention of illegal connections including electrical supply for ceiling fans.
- The prospective bidder shall prepare a design for Backup Power Generator with capacity not less than total computed KVA load without demand factor.
- 3-phase Electrical supply with step down distribution transformer shall be tapped from the nearest existing distribution network/source.

SUBMITTALS: (at suitable scale on high quality 20" x 30" blue print paper minimum size)

- Power Riser Diagram
- Feeder Line System Layout
- Powe System Layout
- Lighting System Layout
- Local Area Network System, if applicable
- Grounding System
- Lightning System Layout
- Load Schedules
- Design Analysis and Computation
- Others as applicable

3.1.3.5. Electromechanical Design

3.1.3.5.1. Fire Protection System

- The prospective bidder shall prepare a design for the Fire Protection system in accordance to the Fire Code of the Philippines, (IRR) of RA 9514, and other relevant laws and ordinances.

SUBMITTALS: (at suitable scale on high quality 20" x 30" blue print paper minimum size)

- Sprinkler System
- Sprinkler System Isometric Diagram
- Sprinkler System Schematic Diagram
- Fire Fighting Piping System Diagram

- Fire Suppression System Layout
- Fire Pump and Jockey Pump equipment schedules
- Fire Reservoir Tank
- Miscellaneous Details
- Others as applicable

3.1.3.5.2. Fire Detection and Alarm System

SUBMITTALS: (at suitable scale on high quality 20" x 30" blue print paper minimum size)

- Fire Alarm System Layout
- Smoke Management System Layout
- Fire Alarm System Layout Schematic Diagram
- Fire Alarm System Layout Isometric Diagram
- Miscellaneous Details
- Others as applicable

3.1.3.6. Other Requirements

- Technical Specifications
- Boring Test
- Structural Design and Analysis and computation
- Final Design and Construction Plans
- Upon award of contract, the Contractor shall comply the following:
 - Prepare final draft of Architectural and Engineering Design Plans incorporating all design refinements and revisions based on project requirement or as may be required by the BuCor PDD - DES within the scope of design.
 - Submit to the BuCor Design and Build Committee (BuCor-DBC) the Final Architectural and Engineering Design Plans and Specifications duly signed and sealed by the concerned Professional Architect, Engineers, incorporating all the necessary revisions and refinements for approval by the Head of Procuring Entity.

3.2 CONSTRUCTION PHASE

The following works shall comprise this phase:

- 3.2.1. Permits and Clearances:** The Contractor shall upon authorization of the Head of the Procuring Entity (HOPE), make representations with the government agencies concerned to expedite the processing of the necessary permits and certificates such as the following:

- Zoning Certification and Locational Clearance
- Building /Electrical/Sanitary Permits
- Certificate of Occupancy
- Environmental Clearance Certificate
- All other permits/clearances as may be required for the construction.

3.2.2. Mobilization: The Contractor shall mobilize all the required project team personnel, equipment, tools, and manpower with the required skills and in sufficient number as may be necessary for his efficient undertaking of the project.

3.2.3. Clearing, Grubbing and Hauling/Disposal of Debris: The contractor shall perform the initial phase of the construction project. Contractor shall remove and dispose of debris, rubbish, landscape waste and all other materials resulting from the site clearing and preparation operations by either recycling, burning, burying, offsite disposal, chipping, creating brush piles, or a combination thereof.

3.2.4. Construction Stage: As a rule, contract implementation guidelines for procurement of infrastructure projects shall comply with Rule II, Section 8 of R.A. 12009 (NGPA) IRR. The following provisions shall supplement these procedures:

3.2.4.1. No works shall commence unless the Contractor has submitted the prescribed documentary requirements and implementing unit has given written approval. Work execution shall be in accordance with reviewed and approved documents.

3.2.4.2. The Contractor shall be responsible for obtaining all necessary information as to risks, contingencies and other circumstances which may affect the works and shall prepare and submit all necessary documents specified by the Implementing Unit to meet all regulatory approvals as specified in the contract documents.

3.2.4.3. The Contractor shall submit a detailed program of works within sixty (60) calendar days after the issuance of the Notice to Proceed (NTP) for approval by the Head of the Procuring Entity (HOPE) that shall include, among others:

- The order in which it tends to carry out the work including anticipated timing for each stage or design/detailed engineering and construction;
- Periods for review of specific outputs and any other submissions and approvals;
- Sequence of timing for inspection and tests;

- General description of the design and construction methods to be adopted;
- Number of personnel to be assigned for each stage of the work;
- List of equipment required on site for each stage of the work; and;
- Description of the quality control system to be utilized for the project.

3.2.4.4. Any errors, omissions, inconsistencies, inadequate or failure submitted by the Contractor that do not comply with the requirements shall be rectified, resubmitted and reviewed at the Contractor's cost. If the Contractor wishes to modify any design or document which has been previously submitted, reviewed and approved, the Contractor shall notify the Implementing Unit within a reasonable period of time and shall shoulder the cost of such changes.

3.2.4.5. As a rule, changes in design and construction requirements shall be limited only to those that have not been anticipated in the contract signing and approval. The following guidelines shall govern approval for a change or variation order:

- Change Orders resulting from design errors, omissions or non-conformance with the performance specifications and parameters and the contract documents by the Contractor shall be implemented by the Contractor at no additional cost to the Bureau of Corrections.
- Provided that the Contractor suffers delay and/or incurs costs due to changes or errors in the preparation of performance specification and parameters, the Contractor shall be entitled to either one of the following:
 - An extension of time for any such delays under Rule XI, Section 71 paragraph 71.1.3 and 71.2.3.
 - Payments for such cost as specified in the contract documents, provided that the cumulative amount of the variation order does not exceed ten percent (10%) of the original contract price. Any cumulative positive Variation Order beyond ten percent (10%) of the original contract price shall be the subject of another procurement project to be bid out if the works are separable from the original contract.

- The contract documents shall include the manner and schedule of payment specifying the estimated contract amount and installments in which the contract will be paid.
- The Contractor shall be entitled to advance payment subject to the provisions of Rule XI, Section 71 paragraph 71.2.5 of the R.A. 12009 IRR.
- The Implementing Unit shall monitor the quality control procedures for the design and construction in accordance with the Government Guidelines and shall issue the proper certificates of acceptance for sections of the works or whole of the works as provided for in the contract documents.
- The Contractor shall provide all necessary equipment, personnel, instruments, documents and others to carry out specified tests.
- This design and build project shall have minimum Defects Liability period of one (1) year contract completion under the provision of Rule XVIII, Section 90 paragraph 90.2.2 of the R.A. 12009 IRR or as provided in the contract documents. This is without prejudice to the liabilities imposed upon the engineer/architect who drew up the plans and specification for a building sanctioned under Article 1723 of the New Civil Code of the Philippines.
- The Contractor shall be held liable for design and structural defects and/or failure of the completed project within the warranty period of 15 years for permanent structures/buildings and 5 years for roads as specified in Rule XVIII, Section 90 paragraph 90.2.2 and 90.2.3 of the R.A.12009 (NGPA) IRR

3.2.5. As-built plans. The Contractor shall cause the preparation and submission of as-built plans duly signed and sealed by all concerned parties involved in the construction in the same sheet size and scale as the original drawings in one (1) blue print copy and one (1) reproducible copy.

3.2.6. General requirements:

3.2.6.1. Temporary facilities such as field offices for the BuCor inspectorate team, project engineers and quarters for laborers; temporary warehouse for the construction material.

3.2.6.2. Office furniture and equipment, survey equipment and consumables.

3.2.6.3. Photographs: This item consists of the supply of equipment and materials, i.e., album, necessary to undertake photographic

progress activities of the project and of all cost incidental to the preparation and submission of photographs (at least 12 photographs per day). The quantities for photographs shall be one (1) set of photographs per month.

3.2.6.4. Health and Safety Program including Personal Protective Equipment (PPE)

- All standard safety measures and precautions shall be exercised by the Contractor in the course of the project for the protection of the public and its workers and in conformity with DOLE Department Order No. 13, Series of 1998.
- All workers shall be equipped with proper working uniform and identification at all times. They must be registered with the governing BuCor Security Office and must comply with the BuCor's Rules and Regulations.
- The Contractor shall secure his/her own equipment and materials on site. The BuCor shall not be liable to any losses incurred during the progress of the work.

3.2.6.5. Minimum Heavy Equipment requirement (as needed) for Site Development such as:

Equipment	Quantity	Purpose
Earthmoving Equipment		
Bulldozer (D6/D7 class)	2	Clearing, grubbing, rough grading
Excavator (0.8 – 1.5 m ³ bucket)	2	Excavation for foundations, trenches, and septic tanks
Backhoe Loader	2	Light excavation, trenching, and loading
Wheel Loader	2	Loading, stockpiling, site clean-up
Motor Grader	1	Road grading, levelling of site roads
Dump Trucks (10-15 cu.m)	3	Hauling soil, aggregates, debris
Compaction Equipment		
Vibratory Road Roller	2	Compacting soil, base, and sub-base layers
Plate Compactor	2	Small area compaction (footpaths, sidewalks)
Concrete and Structural Works		
Transit Mixer (6 cu.m)	2	Concrete delivery on site

Concrete Pump	1	High-rise/long distance concrete placement
Concrete Vibrator	2	Compaction of concrete for structural integrity
Batching Plant (if on-site)	1	On-site concrete production (optional but ideal for large-scale works)
Concrete Pouring Bucket (1.5 cu.m)		
Submersible Dewatering Pump (2 HP single phase 220V)		
Lifting and Handling Equipment		
Mobile Crane (25–50 tons)	1	Lifting of rebar, formwork, roof trusses
Forklift	1	Handling construction materials inside compound
Tower Crane (if multi-story)	1	Optional if structures are multi-level with tight working space
Roadworks and Utility Equipment		
Asphalt Paver	1	Internal road paving
Water Truck	1	Dust control, compaction support
Concrete Cutter	2	Cutting pavement or slabs for utilities
Trenching Machine	1	Efficient trenching for electrical, water, and sewer lines
Additional Temporary Support Equipment		
<ul style="list-style-type: none"> ○ Generator Set – for uninterrupted power during construction ○ Welding Machines – for fabrication on site ○ Scaffolding Sets – for wall and ceiling works ○ Surveying Equipment – Total station, GPS, Theodolite ○ Site Office Containers & Storage 		

Note: Any specified types and/or additional heavy equipment needed to the site development will be determined by the winning bidder.

3.2.6.6. Environmental compliance

3.2.6.7. Communication equipment: This item consists of the provision of communication equipment.

3.2.6.8. Billboard

3.2.6.9. Traffic management (if applicable)

3.2.7. Building Construction

1 lot	One (1) Unit 3-Storey “Type B” PDL Dormitory (20x110) with 50 cells design capacity of 500 PDL with 250 units Double decker Bed Bunks; (see 9.1.4 Type B Dormitory conceptual plan)
1 lot (145 In m more or less)	Partition Fence: with 3 sets of 600mm dia. Concertina/Barb wire steel matting fence with sliding steel control gate with wicket gate. Provided and additional angle bar support and 4 sets of steel bar to reinforce the concertina wires. To include 200w integrated solar street lights every 25 meters and to include Gates); (see 9.1.3 Partition Fence Conceptual Plan).
1 lot	Electrical System: Three phase power supply (shall be tapped from the nearest existing distribution or network/source) includes piping, wirings, fixture, panel boards, circuit breakers, including step down distribution transformers, automatic transfer switch, enclosed circuit breaker and all other necessary item to complete the system. With Backup Power (Three-Phase Genset) supply system with capacity not less than total computed MVA load, without demand factor (designed to supply the entire compound including the future developments), and to include Capacitor Bank, if necessary;
1 lot	Fire Protection System: includes piping, sprinklers, Fire & Jockey Pump, Pump house, Fire Tank, Fire Suppression equipment and all other necessary item to complete the system.
1 lot	Fire Detection and Alarm System: includes piping, wiring, smoke and heat detector and all other necessary item to complete the system.
1 lot	Water Supply System: Provision of a complete water supply system capable of delivering potable water at sufficient pressure. Scope includes all required piping, plumbing fixtures, Pumps Cistern Tank, and an overhead water tank, with connection (tap-in) to the existing water supply source, and all other necessary components for the full completion and operational functionality of the system.

1 lot	Sanitary, Drainage and Vent Systems: Includes all sanitary and drainage piping, Perimeter Catch Basin, Septic Tank installation (to be tapped to the nearest existing point of discharge), and all other necessary components required to complete the system.
1 lot	Site development: Includes Grading and Earthwork levelling the ground and shaping it to the required specifications for the construction project. This may involve excavation, filling and compacting soil.
1 lot	Roadworks: including site preparation, earthworks, construction of sub-base and base layers, concrete pavement.
1 lot	Waterproofing Works: Includes the application of an appropriate waterproofing system at the second-floor toilet, roof deck toilet, and the entire roof deck area.

3.2.7.1. Material Specifications:

3.2.7.1.1 Architectural

- **Dormitory**

Space	Flooring	Tile Size	Wall Finish	Ceiling	Doors / Windows	Notes
Office	Ceramic tiles, matte finish	600mm × 600mm	Painted cement plaster	9mm fiber cement board on metal furring, painted	Aluminum powder-coated windows; Solid panel door	Standard electrical & data provisions
Entrance	Epoxy Floor Coating	None	Painted cement plaster	Exposed ceiling	25 mm Dia Round Bar Metal Grills	Provide signage & directory panel
Frisking Area	Epoxy Floor Coating	None	Painted cement plaster	Exposed ceiling	Steel door; Aluminum windows	Durable, easy-clean surface; anti-slip flooring
Cell	Epoxy Floor Coating	None	Painted cement plaster	Exposed ceiling @ Grnd Floor 4.5 mm Dia Steel Matting @ Second Floor	25 mm Dia Round Bar Metal Grills	Durable, easy-clean surface; anti-slip flooring
Cell toilet	Epoxy Floor Coating	None	Mosaic Tile	Exposed ceiling @ Grnd Floor	25 mm Dia Round Bar Metal Grills	Durable, easy-clean surface; anti-slip flooring

				4.5 mm Dia Steel Matting @ Second Floor		
Hallway	Epoxy Floor Coating	None	Painted cement plaster	Exposed ceiling	N/A	25 mm Dia Round Bar Metal Grills @ Second Floor
Comfort Rooms @ Office	Non-slip ceramic tiles	600mm x 600mm (floor); 300mm x 600mm (walls)	Tiled up to ceiling	Moisture-resistant PVC ceiling	PVC door; Awning window	Standard toilet fixtures, floor drain, exhaust fan
Fire Exit Stair Case	Epoxy Floor Coating	None	25 mm Dia Round Bar Metal Grills	Exposed ceiling	25 mm Dia Round Bar Metal Grills	Fire Resistance Panic Door (Fire Code Provision)
Fire Exit	N/A	N/A	N/A	N/A	N/A	Fire Resistance Panic Door (Fire Code Provision)
Roofing	N/A	N/A	N/A	N/A	N/A	Pre-Painted Roofing and water proofing With Solar Panel
Exterior Walls (General)	N/A	N/A	N/A	N/A	N/A	Basic finish for durability and weather protection

3.2.7.1.2. Waterproofing

- Cementitious – For all second-floor toilet and roof deck toilet.
- UV Resistant Polyurethane Waterproofing For the entire roof deck and elevated water tank area with topping works provided with welded wire mesh.

3.2.7.1.3. Plumbing Works

- uPVC Pipe series 1000 – For all soil, sewer, waste, dry and wet vent piping high-end quality
- PPRC Fusion Type – For all water lines high-end quality

- Plumbing Fixtures
 - Dormitory
 - Stainless Steel- Plumbing Fixtures Material
 - Flush Valve Type shall be used for all Water Closets
 - Offices
 - Ceramic - Plumbing Fixtures Material

3.2.7.1.4. Structural Works

- Concreting

- With water resisting water proofing concrete add mixture and standard structural strength requirements

4. APPROVED BUDGET FOR THE CONTRACT (ABC)

The Approved Budget for the Contract (ABC) is **PhP 300,000,000.00**. This is the ceiling for acceptable bids. Bids higher than ABC shall be automatically rejected.

5. PROPOSED IMPLEMENTATION SCHEDULE (Example):

Months	1	2	3	4	5	6	7	8	9	10	11	12
Design Phase	1	2										
Construction Phase			1	2	3	4	5	6	7	8	9	
Post Construction Phase												1

6. ELIGIBILITY CRITERIA FOR BIDDERS

6.1 General

The eligibility of design and build contractors shall be based on the, technical eligibility documents and financial requirements abovementioned. In the technical requirements, the design and build contractor (as solo or in joint venture/consortia) should be able to comply with the experience requirement under the IRR of R.A. 12009, where one of the parties (in joint venture/consortia) should have at least one similar project, both design and construction, with at least 50% of the cost of the ABC.

If the bidder has no experience in design and builds projects on its own it may enter into partnerships or joint venture with design or engineering firms for the design portion of the contract. For Infrastructure Projects, JV bidders shall submit a JVA in accordance with RA No. 4566 or the “Contractors' License Law” and its IRR. Each partner of the joint venture shall submit their respective

PhilGEPS Certificates of Registration in accordance with Section 20.2.9.1 of this IRR. The submission of technical and financial eligibility documents by any of the joint venture partners constitutes compliance; Provided, That the partner responsible to submit the NFCC shall likewise submit the Statement of all of its ongoing contracts and audited financial statements.

The relevant provisions under Rule VIII Section 52 paragraph 52.4.2.1 of the IRR of R.A. 12009 on eligibility requirements shall be observed. The following persons or entities shall be allowed to participate in the bidding for Infrastructure Projects: a) Duly licensed Filipino citizens or sole proprietorships; b) Partnerships duly organized under the laws of the Philippines and of which at least sixty percent (60%) of the interest belongs to citizens of the Philippines; c) Corporations duly organized under the laws of the Philippines, and of which at least sixty percent (60%) of the outstanding capital stock belongs to citizens of the Philippines; d) Cooperatives duly organized under the laws of the Philippines; or 104 e) Persons or entities forming themselves into a joint venture, i.e., a group of two (2) or more persons or entities that intend to be jointly and severally responsible or liable for a particular contract: Provided, however, That in accordance with EO No. 65, s. 2018, Filipino ownership or interest of the joint venture concerned shall be at least sixty percent (60%): Provided, further, That joint ventures in which Filipino ownership or interest is less than sixty percent (60%) may be eligible where the structures to be built require the application of techniques or technologies which are not adequately possessed by a person or entity meeting the sixty percent (60%) Filipino ownership requirement: Provided, furthermore, That in the latter case, Filipino ownership or interest shall not be less than twenty five percent (25%). For this purpose, Filipino ownership or interest shall be based on the contributions of each of the members of the joint venture as specified in their JVA: Provided, finally, That the primary purpose of each member of the joint venture must be similar or related to the requirement of the project to be bid out.

6.1.1. If the bidder will enter into a subcontracting arrangement the following rules shall apply to locally-funded projects and to projects financed through ODA, except those covered by treaty, or international, or executive agreements

which shall be governed by Section 4.2 of the R.A. 12009 IRR, and under the provision of Rule II, Section 7 paragraph 7.5 of the R.A 12009 IRR.

6.1.2. The approval of the HoPE, upon recommendation by the End-User or Implementing Unit, shall be required for subcontracting. The approval shall include the determination of whether the eligibility documents of the subcontractor will be required as part of the Bid or submitted before the issuance of the Notice of Award.

6.1.3. The subcontracted portion of the contract shall be subject to the approval of the HoPE and the following conditions:

- a. The subcontracted portion shall not exceed twenty percent (20%) for Goods, and fifty percent (50%) for Infrastructure Projects, or a different percentage on a per project basis as approved by the GPPB. The threshold percentages fixed herein shall be subject to the periodic review and adjustments as may be deemed appropriate by the GPPB; and
- b. The subcontracted portion shall be limited to components that are not deemed "significant or material" to the project as determined by the Procuring Entity;

6.1.4. Subcontracting arrangement, if allowed, including the time of submission of the eligibility documents of the subcontractor, shall be disclosed in the Bidding Documents;

6.1.5. Subcontractors must meet the eligibility criteria and shall submit the same eligibility documents as the general contractor. Failure of a subcontractor to meet the eligibility criteria does not affect the eligibility of the general contractor for the procurement project. In such case, the portion intended to be subcontracted to the ineligible subcontractor shall be assumed by the general contractor;

6.1.6. The general contractor shall remain liable for the subcontractor's actions, defaults, delays, and negligence; The general contractor and the subcontractor

are obliged to comply with the provisions of the contract and shall share liability, jointly and severally, in cases of violation of safety standards or other labor standards insofar as the subcontracted portion is concerned; and

6.1.7. For the purpose of post-qualification in accordance with Section 63 of this IRR, the value of the entire completed and accepted project, including the subcontracted portion, shall be credited as experience of the general contractor. In the case of the subcontractor, the following rules shall apply:

6.1.7.1. The subcontractor shall get credit for one hundred percent (100%) of the value of the subcontracted portion of the project performed;

6.1.7.2. Subcontractors shall be eligible to concessional windows of GFIs that treat receivables from the government as loan security; the receivables of subcontractors due from their general contractor shall similarly be accepted as loan security by GFIs; and

6.1.7.3. Contract performance monitoring, such as the use of Constructors Performance Evaluation System (CPES), among others, shall also be mandatorily applied to the work experience of the subcontractors.

6.2 Technical Eligibility Documents

6.2.1. Valid Contractor's License issued by the Philippine Contractor's Accreditation Board

6.2.1.1 Category: **AAA or higher**

6.2.1.2 Classification: **General Building** and/or **Design and Build**

6.2.2. Valid license of the Contractor's designer issued by the Professional Regulation Commission.

6.2.3. Joint Venture Agreements (if applicable)

6.3 Technical Requirements

6.3.1. The Contractor's designer must have designed one structure similar to the project at hand with a construction cost of at least 50 % of the ABC.

6.4 Financial Requirements

The Contractor must have a Net Financial Contracting Capacity (NFCC) at least equal to the ABC to be bid or equivalent to **PhP 300,000,000.00**.

7. CONTENTS OF THE BID

7.1. IN THE FIRST ENVELOPE

7.1.1. Class "A" Documents

7.1.1.1 Technical Documents

- PhilGEPS Certificate of Registration (Platinum membership) in accordance with Section 20 of this IRR of R.A. 12009.
- PCAB License and Registration, in case of Joint Venture (JV);
- Statement of all its ongoing government and private contracts, including contracts awarded but not yet started, if any, whether similar or not similar in nature and complexity to the contract to be bid;
- Statement of the Bidder's SLCC (The SLCC shall be supported by an Owner's Certificate of Final Acceptance issued by the project owner other than the Contractor, or a final rating of at least satisfactory in the CPES, or a similar performance and monitoring system. In case of contracts with the private sector, an equivalent document shall be submitted)
- NFCC Computation;
- Joint Venture Agreement, if applicable;
- Bid security in the prescribed form and amount and validity period;
- Project Requirements, which shall include the following:
 - Organizational chart of the personnel to be deployed for the procurement project to be bid;
 - List of Contractor's personnel (e.g., Project Manager, Project Engineers, Materials Engineers, Safety Officer and Foremen), to be assigned to the procurement project to be bid, with their complete qualifications and experience data.
 - List of Contractor's major equipment units which are owned, leased, or under purchase agreements, supported by proof of ownership or certification of availability of equipment from the equipment lessor or vendor for the duration of the project, as the case may be.

- Omnibus Sworn Statement by the prospective bidder or its authorized representative in the prescribed format;
- Submission of Preliminary Conceptual Design Plans.

7.1.1. Class “B” Documents

7.1.2.1 For Infrastructure Projects, in case the prospective bidders is a joint venture the following documents shall be required:

7.1.2.2 For Infrastructure Projects, JV bidders shall submit a JVA in accordance with RA No. 4566 or the “Contractors’ License Law” and its IRR.

7.1.2.3. Each partner of the joint venture shall submit their respective PhilGEPS Certificates of Registration in accordance with Section 20.2.9.1 of this IRR. The submission of technical and financial eligibility documents by any of the joint venture partners constitutes compliance; Provided, That the partner responsible to submit the NFCC shall likewise submit the Statement of all of its ongoing contracts.

7.1.2.2.1. Preliminary Conceptual Architectural Design Plans in accordance with the degree of details specified by the procuring entity: (at suitable scale on high quality 20x30 inches blue print).

- Location plan/vicinity map
- Utility location
- Perspective
- Floor plans
- Front view elevation
- Rear view elevation
- Left side view elevation
- Right side view elevation
- Longitudinal section
- Transverse section

7.1.2.2.2. Design and Construction Method

7.1.2.2.3. List of contractor’s personnel: To be assigned to the contract to be bid with their complete qualification and experience data and photocopy of their valid licenses issued by the Professional Regulatory Commission (PRC), Curriculum vitae of key staff,

partners or principal officers with a minimum work experience requirements set in the **BDS**;

For Design

The key professionals and the respective qualifications of the DESIGN PERSONNEL shall be as follows:

Principal Architect

The Principal Architect must be duly-licensed with at least ten (10) years' experience in the design of residential, government offices or institutional facilities, and shall preferably be knowledgeable in the application of rapid construction technologies.

Structural Engineer

The Structural Engineer must be a duly-licensed Civil Engineer with at least ten (10) years' experience in structural design, including the design of vertical structures such as buildings and towers, and shall preferably be knowledgeable in the application of rapid construction technologies.

Professional Electrical Engineer

The Electrical Engineer must be a registered Professional Electrical Engineer with at least ten (10) years' experience in the design of lighting, power distribution, communication systems (specifically structured and local area network cabling, PABX), building management systems and preferably knowledgeable in developments in emergent efficient lighting technologies and energy management.

Professional Mechanical Engineer

The Mechanical Engineer must be a Professional Mechanical Engineer with at least ten (10) years in HVAC and fire Protection systems and preferably knowledgeable in emergent, alternative energy- efficient HVAC technologies.

Professional Electronics and Communications Engineer

The Electronics and Communications Engineer must be Professional Electronics and Communications Engineer with at least ten (10) years' experience in the design of communications systems, fire detection and alarm system and preferably knowledgeable in the application of building automation and surveillance systems.

Sanitary Engineer

The Sanitary Engineer must be duly-licensed with at least ten (10) years' experience in the design of building water supply and distribution, plumbing, and preferably knowledgeable in waste water management/treatment, and emergent, alternative effluent collection and treatment system.

The DESIGN & BUILD CONTRACTOR may, as needed and at its own expense, add additional professionals and/or support personnel for the optimal performance of all Architectural and Engineering Design Services, as stipulated in these Terms of Reference, for the PROJECT. Prospective bidders shall attach each individual's resume and PRC license of the (professional) staff with signature.

Design personnel may also be utilized for the construction phase provided that the same meet the minimum number of years of experience in the construction of similar projects.

For Construction Personnel

The key professionals and the respective qualifications of the CONSTRUCTION PERSONNEL shall be as follows:

Project Manager

The Project Manager shall be a licensed architect or engineer with at least ten (10) years relevant experience on similar and comparable projects in different locations. The Project Manager should have a proven record or managerial capability through the directing/managing of major civil engineering works, including projects of a similar magnitude.

Project Architect/Engineer

The Project Architect/Engineer shall be a licensed architect or engineer with at least five (5) years' experience in similar and comparable projects and shall preferably be knowledgeable in the application of rapid construction technologies.

Materials Engineer (M.E. I)

The Materials Engineer must be duly accredited with the DPWH and with at least five (5) years' experience in similar and comparable projects and shall preferably be knowledgeable in the application of rapid construction technologies.

Electrical Engineer

The Electrical Engineer must be duly-licensed with at least five (5) years' experience in similar and comparable projects in the installation of lighting, power distribution, communication systems (specifically structured and local area network cabling, PABX), building management systems.

Electronics and Communication Engineer

The Electronics and Communication Engineer must be duly-licensed with at least five (5) years' experience in similar and comparable projects in the installation of communications systems, fire detection and alarm system and preferably knowledgeable in the application of building automation and surveillance systems.

Mechanical Engineer

The Mechanical Engineer must be duly-licensed with at least five (5) years' experience in similar and comparable projects in the installation of HVAC and fire protection

Sanitary Engineer

The Sanitary Engineer must be duly-licensed with at least five (5) years' experience in similar and comparable projects in the installation of building water supply and distribution, plumbing.

Foreman

The Foreman must have at least ten (10) years' experience in similar and comparable projects and shall preferably be knowledgeable in the application of rapid construction technologies.

Safety officer

The Safety Officer must be an accredited safety practitioner by the Department of Labor and Employment (DOLE) and must have undergone the prescribed forty (40) hour Construction Safety and Health Training (COSH) and must have at least five (5) years' experience.

7.1.2.2.4. Design and Construction Method with Value Engineering Analysis.

7.2 IN THE SECOND ENVELOPE – FINANCIAL PROPOSAL

The second envelope (Financial Proposal) shall contain all the required documents for infrastructure projects under IRR of R.A 12009.

7.2.1. Lump sum bid prices, which shall include the detailed engineering cost, in the prescribed Bid Form inclusive of VAT

7.2.2. Detailed estimates including a summary sheet indicating the unit prices of construction materials, labor rates and equipment rentals used in coming up with the bid for the following:

7.2.2.1. Detailed Architectural and Engineering Design; the cost of which shall not exceed three percent (3%) of the total contract amount of the project;

7.2.2.2. Demolition Works; and

7.2.2.3. Building Construction/Civil Works.

7.2.3. Bill of Quantities

7.2.4. Cash flow and payments schedule.

8. PROCEDURE AND CRITERIA FOR BIDS EVALUATION

For the detailed evaluation of the design and build proposals a two-step procedure shall be adopted by the BAC, which may be undertaken with the assistance of the DBC.

First-Step Procedure:

The first step of the bids evaluation shall consist of a detailed technical evaluation of all bids to determine their responsiveness and compliance with the Employer's Requirements and the Technical Specifications, in accordance with the Implementing Rules and Regulations (IRR) of applicable procurement laws and the Philippine Bidding Documents (PBDs) for Infrastructure Projects.

During this stage, only the Technical Proposals of bidders who passed the preliminary examination shall be evaluated. The objective of the technical evaluation is to assess the bidder's technical capability, design soundness, construction methodology, innovation, sustainability measures, personnel competence, and relevant experience, to ensure the successful delivery of the project in terms of quality, safety, functionality, and sustainability.

The BAC shall evaluate the quality proposals to determine the MEARB using the quality components provided in Section 61.4 of this IRR. The quality components shall be assessed on the basis of the criteria with corresponding numerical weights indicated in the bidding document to determine the bidder with the highest technical rating.

The technical evaluation shall be conducted using the following criteria, each with corresponding indicators and scoring methodology as prescribed in the Bidding Documents:

- Quality and Technical Merit
Including demonstrated technical competence, compliance with specifications, and a credible track record in similar projects.
- Aesthetic and Functional Design
Soundness of design, functionality, efficiency, durability, and appropriateness to the intended use of the goods or infrastructure.
- Approach and Methodology
Clarity, feasibility, and effectiveness of the proposed implementation approach, work plan, and methodology.
- Accessibility
Compliance with applicable accessibility laws and standards (e.g., universal design, PWD-friendly features), where applicable.

- Tools and Equipment
Adequacy, availability, condition, and suitability of tools, machinery, and equipment to be used for contract execution.
- Social, Environmental, Economic, and Innovative Characteristics
Extent to which the proposal promotes sustainability, environmental protection, social responsibility, cost efficiency, and innovative solutions.
- Organization, Qualification, and Experience of Personnel
Competence, qualifications, experience, and organizational structure of key personnel assigned to perform the contract.
- Ongoing Contracts and Work Commitments
Assessment of current workload and capacity to undertake and complete the project within the prescribed schedule.
- After-Sales Service and Technical Assistance
Availability, responsiveness, and adequacy of warranty, maintenance, training, and technical support services.
- Delivery Conditions
Proposed delivery period, logistics, scheduling, and delivery process, including risk mitigation measures.
- Disposal Measures
Compliance with applicable laws and standards on waste management, disposal, and environmental protection, where applicable.
- Other Relevant Criteria
Other factors directly related to the nature and requirements of the Goods or Infrastructure Project being procured, as determined by the End-User.

Second-Step Procedure:

The second bid envelope of the bidder obtaining the top three (3) highest technical rating shall be opened. If the financial proposal is equal to or lower than the ABC, the bid shall be accepted and determined as the MEAB; otherwise, the same shall be rejected and the bidder will be disqualified. The specific terms and conditions for using the MEARB as an award criterion shall be specified in the guidelines to be issued by the GPPB.

9. DATA TO BE PROVIDED BY THE BUCOR

These data are for reference only and do not guarantee the Contractor that the information provided is correct, free from error, or applicable to the project at

hand. The Contractor shall be responsible for verifying the accuracy and applicability of any data used in his design-build proposal and related services. Sample Data:

9.1. Vicinity Map (Coordinates 9.746930280153514, 118.65243154483957)



9.2. Site Development

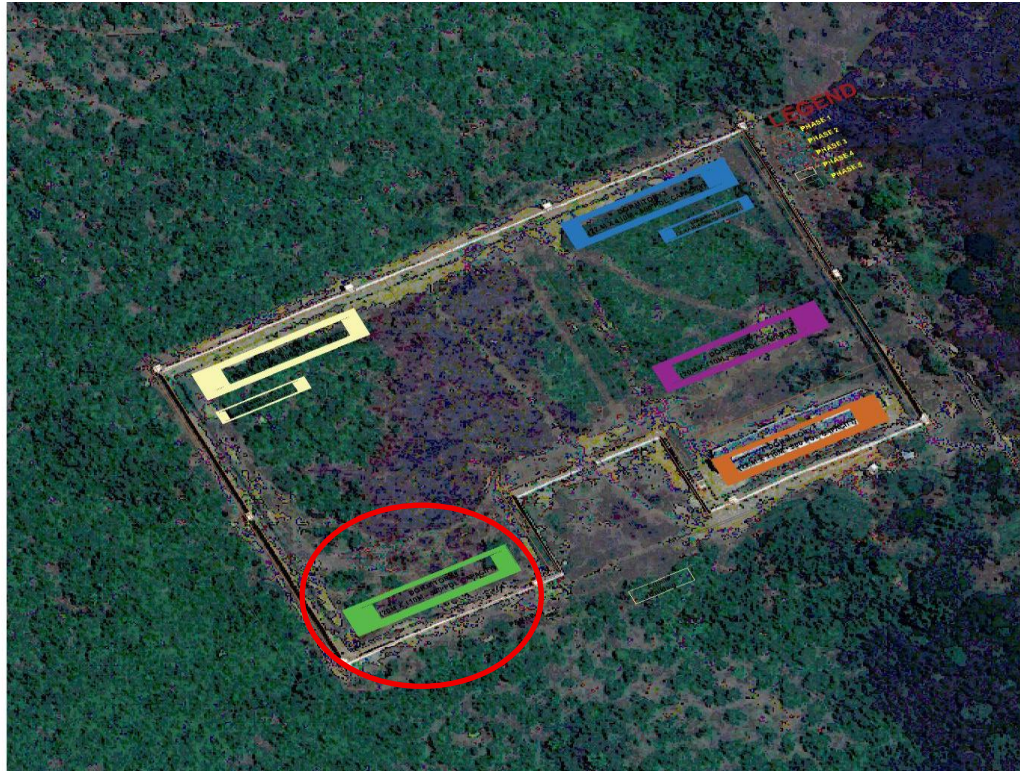

9.1.3. PARTITION FENCE CONCEPTS

Partition Fence Plan:

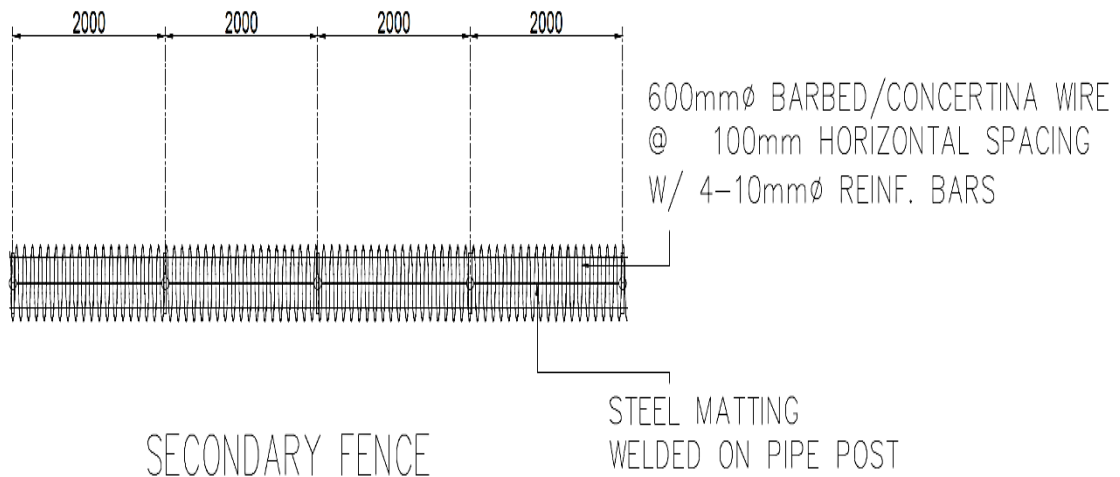

SECONDARY FENCE
 BLOW-UP ELEVATION



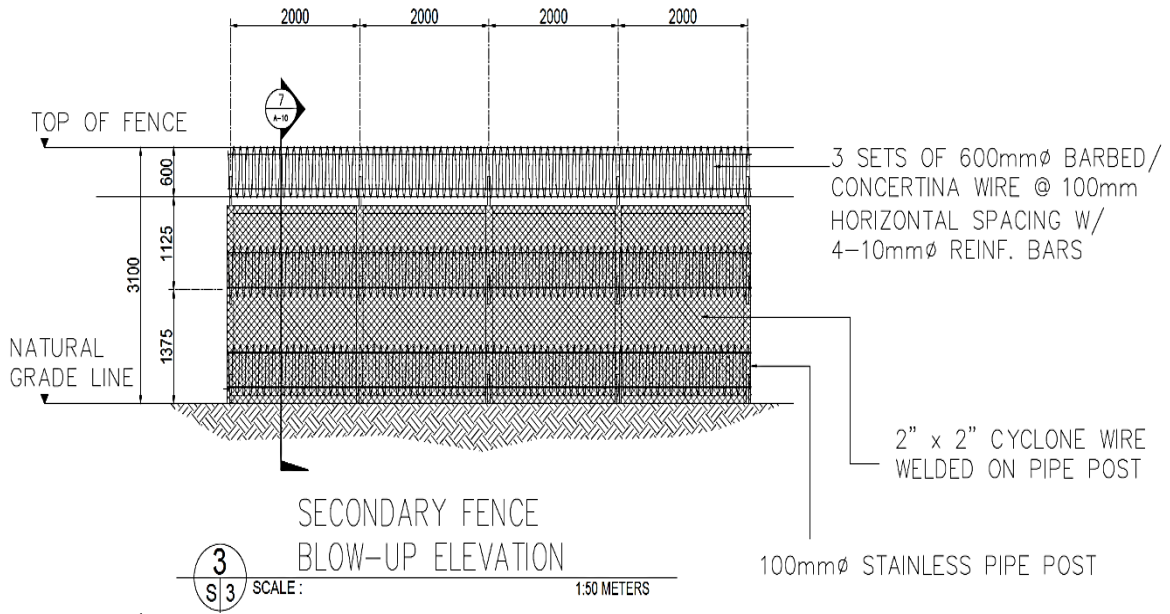

Partition Fence Gate Elevation:

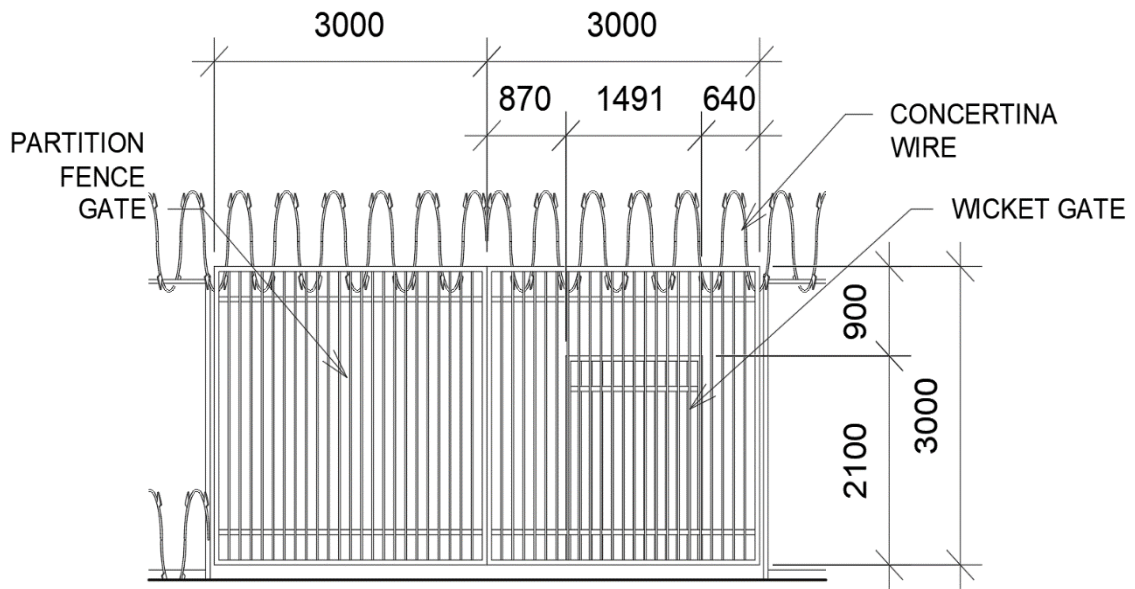

9.1.4 Type B Dormitory



EXTERIOR PERSPECTIVE (FRONT)



EXTERIOR PERSPECTIVE (TOP)



INTERIOR PERSPECTIVE (ROOF DECK)

Type B Dormitory (Floor Plan)

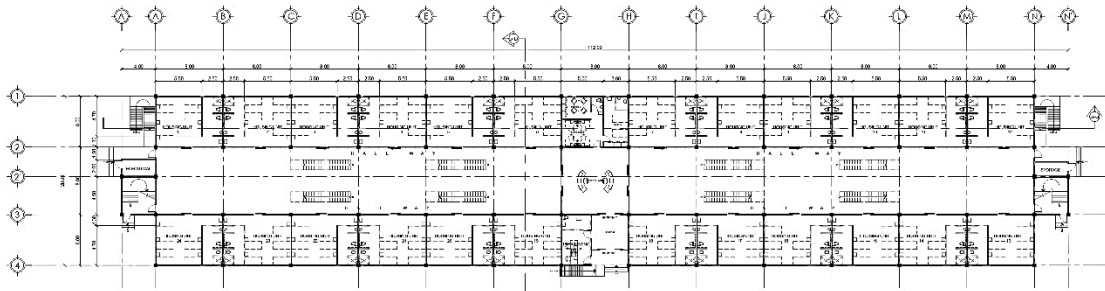

GROUND FLOOR PLAN

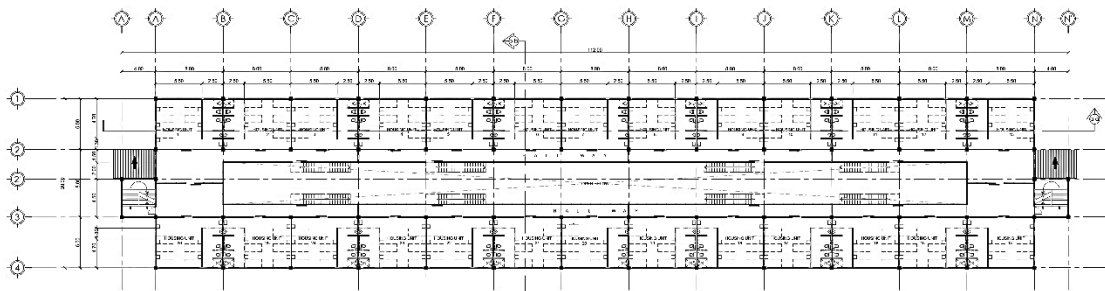

SECOND FLOOR PLAN

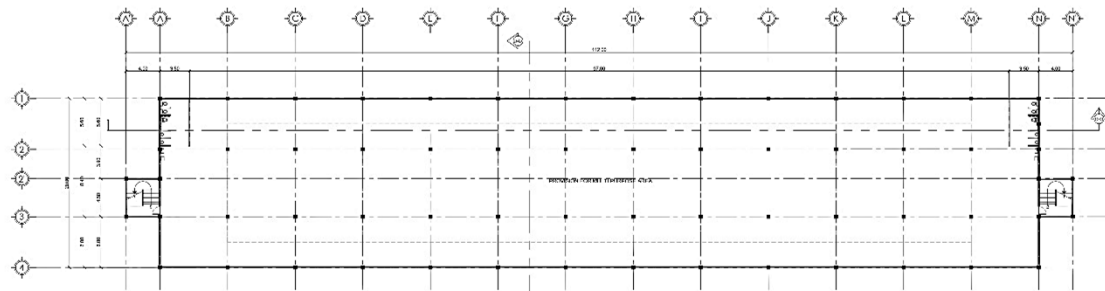

ROOF DECK PLAN

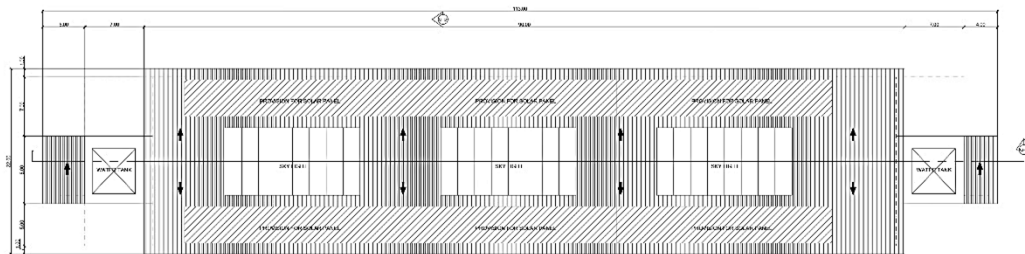

ROOF PLAN

10. DOCUMENTS TO BE PROVIDED BY THE CONTRACTOR DURING CONTRACT IMPLEMENTATION

During the implementation of Design and Build of BuCor Regional Facility – One (1) Unit, 3-Storey Type B Dormitory – Phase 5 (IPPF) in Puerto Princesa City, Palawan, the Contractor shall be required to submit the following documents to the Bureau of Corrections (BuCor) and/or its authorized representatives in a timely manner, subject to review, approval, and compliance with applicable regulations:

10.1. Detailed Architectural and Engineering (A&E) Plans

- Complete signed and sealed plans for all disciplines (Architectural, Structural, Civil, Sanitary/Plumbing, Electrical, Mechanical, Fire Protection, and ICT).
- Printed sets (20 x 30) and soft copies in both PDF and editable CAD format.

10.2. Design Calculations and Technical Specifications

- Structural analysis, electrical and mechanical load computations, water demand, and HVAC sizing
- Compliance matrix with BuCor design standards and national codes

10.3. Bill of Quantities (BOQ) and Cost Estimates

- Itemized and priced based on final approved drawings
- Must be consistent with submitted work program

10.4. Construction Schedule and Work Breakdown Structure (WBS)

- PERT/CPM or Gantt chart with clear milestones and activity timelines
- Manpower and equipment deployment plan

10.5. Shop Drawings and Fabrication Details (as required)

- For precast, structural connections, steel works, cabinetry, mechanical systems, etc.

10.6. Detailed Geotechnical Investigation Report

10.7. Design Report.

10.8. Statutory and Regulatory Compliance

- 10.8.1. Approved Building Permit and Ancillary Permits
- 10.8.2. Environmental Compliance Certificate (ECC) or Certificate of Non-Coverage (CNC) (if applicable)
- 10.8.3. Contractor's All Risk Insurance (CARI)
- 10.8.4. Performance Security and Warranty Security
- 10.8.5. Fire Safety Inspection Clearance (upon completion)

10.9. Progress and Administrative Reports

- 10.9.1. Monthly Progress Reports
- 10.9.2. Weekly Site Meeting Minutes
- 10.9.3. Updated Construction Schedule (Monthly)

10.10. Completion and Turnover Documents

- 10.10.1. As-Built Drawings
 - 10.10.1.1. Signed and sealed, both printed and soft copies (PDF and CAD formats)
- 10.10.2. Operation and Maintenance (O&M) Manuals
 - 10.10.2.1. For all installed systems, including warranties and contact information
- 10.10.3. Final Commissioning and Testing Certificates
- 10.10.4. Affidavit of Completion and Request for Final Inspection
- 10.10.5. Certificate of Final Acceptance (Issued by BuCor upon successful inspection and verification)
- 10.10.6. Warranty Certificate
 - 10.10.6.1. Equipment
 - 10.10.6.2. Structure

10.11. Other relevant documents

All submissions shall be made in both **printed and digital formats**, and must be properly indexed, labeled, and accompanied by transmittals. Late, incomplete, or non-compliant submissions may result in delays in billing approval, withholding of payments, or imposition of penalties in accordance with the contract.

11. DESIGN AND BUILD PERIOD

The Winning Bidder shall commence actual works upon the issuance by the BUCOR of the Notice to Proceed (NTP).

The Winning Bidder shall finalize and submit the Detailed Architectural and Engineering Design (DAED) and all necessary permits to the BuCor within sixty (60) calendar days for review and approval. The contractor shall complete the construction of the building within Two Hundred Seventy - Five (275) calendar days, and Thirty (30) calendar days for the post construction, for a total contract duration of three hundred sixty-five (365) calendar days. Failure of the contractor to comply within the required specific period, without any fault of the Procuring Entity, shall be a valid ground for termination of contract.

CONFORME:

Name of Company in Print

Signature Over Printed Name of Authorized Representative/Date

Section VII. Drawings

The Conceptual Drawings should be attached to this section as part of the first envelope (Technical Component Envelope).

Preliminary Conceptual Architectural Design Plans in accordance with the degree of details specified by the procuring entity:
at suitable scale on high quality 20x30 inches blue print in digital format.

1. Location plan/vicinity map
2. Utility location
3. Perspective
4. Floor plans
5. Front view elevation
6. Rear view elevation
7. Left side view elevation
8. Right side view elevation
9. Longitudinal section
10. Transverse section

Section VIII. Bill of Quantities

The Bill of Quantities should be attached to this section as part of the second envelope (Financial Component Envelope)

Section IX. Philippine Bidding Documents Related Forms

COMPANY LETTERHEAD

Statement of ongoing government & private contracts

**Design and Build of BUCOR Regional Facility One (1) Unit 3-Storey Type B
Dormitory- Phase 5**

Statement of all its ongoing government and or private contracts including contracts awarded but not yet started, if any whether similar or not similar in nature.

Name of Contract	Date of contract	Contract Duration	Owner's Name and Address	Nature of work	contractor's role (whether sole contractor, subcontractor, or partner in a JV) and percentage of participation	total contract value at award	date of completion or estimated completion time	value of outstanding works

CERTIFIED CORRECT:

Name and Signature of Authorized Representative

Position

Date

COMPANY LETTERHEAD

Statement of Single Largest Completed Contract

**Design and Build of BUCOR Regional Facility One (1) Unit 3-Storey Type B
Dormitory- Phase 5**

Statement of Single (1) Largest Completed Contract of Similar in nature within the last four (4) years from the date of submission and receipt of bids amounting to at least fifty percent (50%) of the Approved Budget of the Contract (ABC)

Name of Contract	Date of contract	Contract Duration	Owner's Name and Address	Nature of work	contractor's role (whether sole contractor, subcontractor, or partner in a JV) and percentage of participation	total contract value at award	Amount of completed contracts, adjusted by the Bidder to current prices using PSA's consumer price index, if necessary	date of completion or estimated completion time

CERTIFIED CORRECT:

Name and Signature of Authorized Representative

Position

Date

COMPANY LETTERHEAD

Certificate of Net Financial Contracting Capacity

**Design and Build of BUCOR Regional Facility One (1) Unit 3-Storey Type B
Dormitory- Phase 5**

(Please show figures at how you arrived at the NFCC)

This is to certify that our Net Financial Contracting Capacity (NFCC) is _____ (P_____) which is at least equal to the total ceiling price we are bidding. The amount is computed as follows: (Please show computation of NFCC)

$$NFCC = (CA-CL) (15) - C$$

Where:

CA = Current Assets

CL = Current Liabilities

C = value of all outstanding or uncompleted portions of the
Projects under going contracts, including awarded contracts
Yet to be started coinciding with the contract for this Project

NOTE:

The values of the bidder's current assets and current liabilities shall be based on the Audited Financial Statement submitted to the BIR.

Issued this _____ day of _____, 2026

Name & Signature of Authorized Representative

Position

Date

Bid Securing Declaration Form

*[The duly accomplished form shall be submitted with the Bid
if bidder opts to provide this type of bid security]*

REPUBLIC OF THE PHILIPPINES)
CITY/MUNICIPALITY OF _____) S.S.

BID SECURING DECLARATION

Project Identification No.: *[Number]*

To: *[Insert name of the Procuring Entity]*

I/We, the undersigned, declare that:

- 1) I/We understand that, according to your conditions, bids must be supported by a Bid Security, which may be in the form of a Bid Securing Declaration;
- 2) I/We accept that:
 - a) I/We shall enter into contract with the Procuring Entity and furnish the required performance security within ten (10) calendar days as indicated in the Bidding Documents, from receipt of the Notice of Award;
 - b) I/we will be automatically disqualified from bidding for any procurement contract with any Procuring Entity upon receipt of your Blacklisting Order; and
 - c) I/We will pay the applicable fine within fifteen (15) days from receipt of the written demand by the Procuring Entity for the commission of acts resulting to the enforcement of the Bid Securing Declaration under Sections 52.2 (a), 63.2, 69.1 and 100, except 100.3 (c), of the IRR of RA No. 12009; without prejudice to other legal action the government may undertake;

	<i>Applicable Fine</i>
a) in the case of a single bidder	i) two percent (2%) of the Approved Budget for the Contract (ABC); or ii) the difference between the evaluated bid price and the ABC whichever is higher
b) in the case of multiple bidders	i) two percent (2%) of the ABC; or

	ii) the difference between the evaluated bid prices with the bidder with Lowest Calculated/Highest Rated Bid and the bidder with the next Lowest Calculated/Highest Rated Bid, and so on whichever is higher
c) in case of violations committed prior to the opening of the financial envelope	i) a fixed amount of two percent of the ABC,

- 3) I/We understand that this Bid Securing Declaration shall cease to be valid on the following circumstances:
- a) Upon expiration of the bid validity period, or any extension thereof pursuant to your request;
 - b) I am/we are declared ineligible or post-disqualified upon receipt of your notice to such effect, and (i) I/we failed to timely file a request for reconsideration or (ii) I/we filed a waiver to avail of said right;
 - c) I am/we are declared the bidder with the *[Insert Award Criterion¹]* and I/we have furnished the performance security and signed the Contract.

IN WITNESS WHEREOF, I/We have hereunto set my/our hand/s this ____ day of *[month]* *[year]* at *[place of execution]*.

Duly authorized to sign the Bid for and behalf of:

[Insert Bidder's Name]

[Signature over Printed Name]

[Position/Designation]

[Date]

Omnibus Sworn Statement Form

[Note: The duly accomplished form shall be submitted with the Bid]

REPUBLIC OF THE PHILIPPINES)
CITY/MUNICIPALITY OF _____) S.S.

OMNIBUS SWORN STATEMENT

I, [Name of Affiant], of legal age, [Civil Status], [Nationality], and with residence at [Address of Affiant], after having been duly sworn in accordance with law, do hereby depose and state that:

1) *Select one, delete the others:*

- *If sole proprietorship:* I am the sole proprietor or authorized representative of [Name of Bidder] with office address at [Address of Bidder];
- *If partnership, corporation, cooperative, or joint venture:* I am the duly authorized and designated representative of [Name of Bidder] with office address at [Address of Bidder];
- *If individual consultant not registered under a sole proprietorship, in case of Consulting Services:* I am the individual consultant or authorized representative of [Name of Bidder] with office address at [Address of Bidder];

2) *Select one, delete the others:*

- *If sole proprietorship:* As the owner and sole proprietor or authorized representative of [Name of Bidder], I have full power and authority to do, execute and perform any and all acts necessary to participate, submit the bid, and to sign and execute the ensuing contract for [Project Title] of the [Name of the Procuring Entity] [insert "as supported by the attached duly notarized Special Power of Attorney" for authorized representative];
- *If partnership, corporation, cooperative, or joint venture:* I am granted full power and authority to do, execute and perform any and all acts necessary to participate, submit the bid, and to sign and execute the ensuing contract for [Project Title] of the [Name of the Procuring Entity], as supported by the attached duly notarized Special Power of Attorney, Board/Partnership Resolution, or Secretary's Certificate, whichever is applicable;
- *If individual consultant not registered under a sole proprietorship, in case of Consulting Services:* As the individual consultant or authorized representative of [Name of Bidder], I have full power and authority to do, execute and perform any and all acts necessary to participate, submit the bid, and to sign and execute the

ensuing contract for *[Project Title]* of the *[Name of the Procuring Entity]*, as supported by the attached duly notarized Special Power of Attorney for authorized representative;

- 3) *[Name of Bidder]* is not “blacklisted” or barred from bidding by the Government of the Philippines or any of its agencies, offices, corporations, or Local Government Units, foreign government/foreign or international financing institution whose blacklisting rules have been recognized by the Government Procurement Policy Board; by itself or by relation, membership, association, affiliation, or controlling interest with another blacklisted person or entity;
- 4) Each of the documents submitted in satisfaction of the bidding requirements is an authentic copy of the original, complete, and all statements and information provided therein are true and correct;
- 5) *[Name of Bidder]* is authorizing the Head of the Procuring Entity or its duly authorized representative(s) to verify all the documents submitted;
- 6) *Select one, delete the others:*
 - *If sole proprietorship:* The *[Name of Bidder]* and its spouse are not related by consanguinity or affinity up to the third civil degree to the Head of the Procuring Entity, Procurement Agent (if engaged), End-User or Implementing Unit, project consultants, head of the Project Management Office, or the members of the Bids and Awards Committee (BAC), the Technical Working Group, and the BAC Secretariat;
 - *If partnership:* The partnership itself and the partners of *[Name of Bidder]* are not related by consanguinity or affinity up to the third civil degree to the Head of the Procuring Entity, Procurement Agent (if engaged), End-User or Implementing Unit, project consultants, head of the Project Management Office, or the members of the Bids and Awards Committee (BAC), the Technical Working Group, and the BAC Secretariat;
 - *If cooperative:* The cooperative itself and members of the board of directors, general manager, or chief executive officer of *[Name of Bidder]* are not related by consanguinity or affinity up to the third civil degree to the Head of the Procuring Entity, Procurement Agent (if engaged), End-User or Implementing Unit, project consultants, head of the Project Management Office, or the members of the Bids and Awards Committee (BAC), the Technical Working Group, and the BAC Secretariat;
 - *If corporation, or joint venture:* The corporation or joint venture itself, and officers, directors, and controlling stockholders of *[Name of Bidder]* are not related by consanguinity or affinity up to the third civil degree to the Head of the Procuring Entity, Procurement Agent (if engaged), End-User or Implementing Unit, project consultants, head of the Project Management Office, or the members of the Bids and Awards Committee (BAC), the Technical Working Group, and the BAC Secretariat;
 - *If individual consultant not registered under a sole proprietorship, in case of Consulting Services:* The individual consultant and its spouse are not related by

consanguinity or affinity up to the third civil degree to the Head of the Procuring Entity, Procurement Agent (if engaged), End-User or Implementing Unit, project consultants, head of the Project Management Office, or the members of the Bids and Awards Committee (BAC), the Technical Working Group, and the BAC Secretariat;

- 7) It is understood that failure to faithfully disclose its relationship with the HoPE, members of the BAC, the TWG, and the BAC Secretariat, the head of the PMO or the end-user unit or implementing unit, and the project consultants of the Procuring Entity, or of the procurement agent by consanguinity or affinity up to the third civil degree, as well as its submission of beneficial ownership information containing false entries shall be subject to blacklisting under Section 100 of the IRR of RA No. 12009, without prejudice to criminal and civil liabilities under applicable laws, including their accessory penalties, if any.

Select one, delete the rest:

- *In case of corporations: [Name of Bidder] declares its beneficial ownership information consistent with its updated General Information Sheet or Beneficial Ownership Declaration Form or any other document duly submitted to the SEC and has maintained a valid and updated file therein in compliance with Sections 20.2.9.1, 81, and 82 of the IRR of Republic Act (RA) No. 12009.*
- *In case of Foreign Bidders: [Name of Bidder] submitted an appropriate equivalent document in English issued by the country of the bidder concerned in accordance with Section 20.2.9.2 of the IRR of RA No. 12009.*

- 8) *[Name of Bidder] complies with existing labor laws and standards; and*

- 9) *[Name of Bidder] is aware of and has undertaken the following responsibilities as a Bidder:*

- a) Carefully examine all of the Bidding Documents;
- b) Acknowledge all conditions, local or otherwise, affecting the implementation of the Contract;
- c) Made an estimate of the facilities available and needed for the contract to be bid, if any; and
- d) Inquire or secure Supplemental Bid Bulletin(s) issued for the *[Project Title]*.

- 10) *[Name of Bidder] did not give or pay directly or indirectly, any commission, amount, fee, or any form of consideration, pecuniary or otherwise, to any person or official, personnel or representative of the government in relation to any procurement project or activity.*

- 11) *In case advance payment was made or given to [Name of Bidder], failure to perform or deliver any of the obligations and undertakings in the contract shall be sufficient grounds to constitute criminal liability under existing laws.*

IN WITNESS WHEREOF, I have hereunto set my hand this ___ day of ___, 20__ at _____, Philippines.

Duly authorized to sign the Bid for and behalf of:

[Insert Bidder's Name]

[Affiant's Signature over Printed Name]

[Position/Designation]

[Date]

JURAT

SUBSCRIBED AND SWORN to before me this _____ day of *[month]* *[year]* at *[place of execution]*, Philippines. Affiant/s is/are personally known to me and was/were identified by me through competent evidence of identity as defined in the 2004 Rules on Notarial Practice (A.M. No. 02-8-13-SC). Affiant/s exhibited to me his/her *[insert type of government identification card used]*, with his/her photograph and signature appearing thereon, with no. _____.

WITNESS MY HAND AND SEAL this ____ day of *[month]* *[year]*.

NAME OF NOTARY PUBLIC

Notarial Commission No. _____

Notary Public for _____ until _____

Roll of Attorneys No. _____

PTR No. __, *[date issued]*, *[place issued]*

IBP No. __, *[date issued]*, *[place issued]*

Doc. No. _____

Page No. _____

Book No. _____

Series of _____.

Bid Form for Procurement of Infrastructure Projects

[Note: The duly accomplished form shall be submitted with the Bid]

BID FORM

Project Identification No.: *[Insert number]*

To: *[Name of Procuring Entity]*

Having examined the Philippine Bidding Documents (PBD) including the Supplemental Bid Bulletin Numbers *[insert numbers]*, the receipt of which is hereby duly acknowledged, we, the undersigned, declare that:

- a) I/We have no reservation to the PBD, including the Supplemental Bid Bulletins, for the Procurement Project *[Project Title]*;
- b) I/We offer to execute the Works for this Contract in accordance with the PBD;
- c) The total price of our Bid in words and figures, excluding any discount offered below, is *[insert information]*
- d) The discounts offered and the methodology for their application, if any, are: *[insert information]*; or indicate N/A if no discount offered
- e) The total bid price in words and figures, after applying the applicable discount, includes the cost of all taxes, such as, but not limited to *[specify the applicable taxes, e.g. (i) value added tax (VAT), (ii) income tax, (iii) local taxes, and (iv) other fiscal levies and duties]*, which are itemized in the Detailed Estimates.
- f) This Bid shall remain valid within a period stated in the PBD, and it shall be binding upon me/us at any time before the expiration of that period;
- g) If our bid is accepted, I/we commit to enter to a contract and provide a performance security in the form, amounts, and within the times prescribed in the PBD, and hereby acknowledge the consequences under the IRR of RA No. 12009 on forfeiture of Bid Security or enforcement of Bid Securing Declaration and on Blacklisting.

Until a formal Contract is prepared and executed, this Bid, together with your written acceptance thereof and your Notice of Award, shall be binding upon the Bidder.

I/We understand that you are not bound to accept the Lowest Calculated Bid or any Bid you may receive.

I/We certify/confirm that we comply with the eligibility requirements pursuant to the PBD.

The undersigned is authorized to submit the bid on behalf of *[Name of the Bidder]* as evidenced by the attached *[State the Written Authority]*.

I/We acknowledge that failure to sign each and every page of this Bid Form, including the attached Schedule of Prices, shall be a ground for the rejection of our bid.

Duly authorized to sign the Bid for and behalf of:

[Insert Bidder's Name]

[Signature over Printed Name]

[Position/Designation]

[Date]

Checklist of Technical and Financial Documents

First Envelope

The first bid envelope shall contain the following technical documents, including the eligibility documents:

1	PhilGEPS Certificate of Registration (Platinum Membership) in accordance with Section 20 of the IRR;
2	PCAB License and Registration. In case of Joint Venture Agreement (JVA), Special PCAB License and Registration must be submitted.
3	Statement of all its ongoing government and private contracts, including contracts awarded but not yet started, if any, whether similar or not similar in nature and complexity to the contract to be bid;
4	Statement of the Bidder's SLCC, in accordance with ITB Clause 5.5. The SLCC shall be supported by an Owner's Certificate of Final Acceptance issued by the project owner other than the Contractor, or a final rating of at least satisfactory in the CPES, or a similar performance and monitoring system. In case of contracts with the private sector, an equivalent document shall be submitted;
5	NFCC computation in accordance with ITB Clause 5.6;
6	Joint Venture Agreement (JVA), if applicable;
7	Bid Security in the prescribed form and amount in accordance with ITB Clause 16, and validity period under ITB Clause 15;
8	Project Requirements, which shall include the following:
A	Organizational chart of the personnel to be deployed for the procurement project to be bid;
B	List of contractor's key personnel (e.g., Project Manager, Project Engineers, Materials Engineers, and Foremen), to be assigned to the contract to be bid with their complete qualification and experience data and photocopy of their valid licenses issued by the professional regulatory Commission (PRC) and Curriculum vitae of key staff, partners or principal officers with a minimum work experience requirements set in the BDS
C	List of Contractor's major equipment units which are owned, leased, or under purchase agreements, supported by proof of ownership or certification of availability of equipment from the equipment lessor or vendor for the duration of the project, as the case may be, which must meet the minimum requirements for the contract set in the BDS ; and
9	Omnibus Sworn Statement in accordance with Section 54.3 of the IRR.

	10	Conformity with the Technical Specifications (Scope of Work);
	11	<p>Preliminary Conceptual Architectural Design Plans in accordance with the degree of details specified by the procuring entity: at suitable scale on high quality 20x30 inches blue print.</p> <ol style="list-style-type: none"> 1. Location plan/vicinity map 2. Utility location 3. Perspective 4. Floor plans 5. Front view elevation 6. Rear view elevation 7. Left side view elevation 8. Right side view elevation 9. Longitudinal section 10. Transverse section
	12	Design and Construction Method with Value Engineering Analysis
	13	<p>The bidder shall conduct Soil Test from a DPWH accredited third party/laboratory. Number of boreholes shall comply to the National Structural Code of the Philippines (NSCP).</p> <p>The bidder shall submit the soil test result with the test certificate.</p>
	14	Certificate of Site Inspection signed by the OPPF Superintendent.
	15	Affidavit of Site Inspection

Second Envelope

The second bid envelope shall contain the Financial Bid Form, which includes the bid prices and the bill of quantities, in accordance with ITB Clauses 13.1.

	1	Original of duly signed and accomplished Financial Bid Form
	2	Original of duly signed Bid Prices in the Bill of Quantities
	3	Duly accomplished Detailed Estimates Form, including a summary sheet indicating the unit prices of construction materials, labor rates, and equipment rentals used in coming up with the Bid;
	4	Cash Flow and Payment schedule

